

CARBON-FREE COMPRESSED AIR ENERGY STORAGE

by

Dustin Shively

A thesis

submitted in partial fulfillment

of the requirements for the degree of

Master of Science in Mechanical Engineering

Boise State University

December 2009

2009

Dustin Shively

ALL RIGHTS RESERVED

BOISE STATE UNIVERSITY GRADUATE COLLEGE

DEFENSE COMMITTEE AND FINAL READING APPROVALS

of the thesis submitted by

Dustin Shively

Thesis Title: Carbon-Free Compressed Air Energy Storage

Date of Final Oral Examination: 23 October 2009

The following individuals read and discussed the thesis submitted by student Dustin Shively, and they evaluated his presentation and response to questions during the final oral examination. They found that the student passed the final oral examination.

John Gardner, Ph.D.	Chair, Supervisory Committee
James Ferguson, Ph.D.	Member, Supervisory Committee
Don Plumlee, Ph.D.	Member, Supervisory Committee
David Solan, Ph.D.	Member, Supervisory Committee
Todd Haynes	Member, Supervisory Committee

The final reading approval of the thesis was granted by John Gardner, Ph.D., Chair of the Supervisory Committee. The thesis was approved for the Graduate College by John R. Pelton, Ph.D., Dean of the Graduate College.

ABSTRACT

The inherent intermittency of the two fastest growing renewable energy sources, wind and solar, presents a significant barrier to widespread penetration and replacement of fossil-fuel sourced baseload generation. These intermittencies range from short term ramp events experienced by wind farms to the diurnal fluctuation of solar installations. Traditionally, grid operators have had very little control over demand and full control over supply. With the increase in wind and solar based generation onto an electric grid comes a decrease in control of supply. Grid operators are required to have a certain amount of spinning reserve ready to respond when wind or solar resources suddenly decrease. One solution to this problem of grid integration is the use of energy storage. While traditionally used as merchant facilities to buy and sell energy on the spot market, storage is actively being investigated as a means of enabling renewable energy sources to achieve widespread penetration onto national grids. Pumped hydro storage has been used extensively as a means of large scale energy storage. Standard compressed air energy storage (CAES), while only two installations currently exist, shows potential to store large amounts of energy. Both traditional technologies have drawbacks; they are site specific, and in CAES, require natural gas combustion.

In this thesis, a short-to-medium term energy storage system is presented. While similar to the CAES technique in that compressed air is still used for energy storage, it differs as an incompressible liquid is the working fluid in the turbine, thus eliminating the need for supplementary combustion when the energy is recovered. Energy is stored above ground in pressure tanks until power is needed; at this time, it exerts a force on the incompressible fluid, pushing it through a hydroturbine. This family of approaches combines the best concepts attributed with pumped hydro storage and CAES in a system that is not site-specific, does not require natural gas and has the potential for being very efficient.

Thermodynamic analyses were performed to determine energy flows into and out of the system. The results from that analysis were used to verify a system model created from individual component models. This system model was then used to simulate the application of this energy storage technology in various applications and accurately assess its performance.

This research found that this approach to energy storage is feasible with existing technology. The upper bound on the round-trip efficiency of energy stored in this manner is 65%.

TABLE OF CONTENTS

ABSTRACT.....	IV
LIST OF TABLES.....	IX
LIST OF FIGURES.....	X
INTRODUCTION.....	1
EXISTING ENERGY STORAGE SYSTEMS.....	4
TRADITIONAL COMPRESSED AIR ENERGY STORAGE.....	4
PUMPED HYDRO.....	7
BATTERIES, FUEL CELLS & FLYWHEELS.....	8
PROPOSED ENERGY STORAGE SYSTEMS.....	10
CARBON-FREE COMPRESSED AIR ENERGY STORAGE.....	11
THERMODYNAMIC ANALYSIS.....	14
MODELING.....	20
COMPRESSOR.....	20
TANK.....	22
TURBINE.....	24
LOGIC.....	25
SYSTEM.....	26

OPERATIONAL CYCLE	28
PRESSURIZE	29
EXTRACT	29
LOOP.....	29
FILL	36
PARAMETERS	37
OPERATION	38
BATCH OPERATION.....	38
APPLICATION STUDIES.....	40
GRID OPERATORS	41
RENEWABLE ENERGY ELECTRICITY GENERATION OPERATOR.....	44
MERCHANT STORAGE FACILITY	47
CONCLUSIONS AND FURTHER RESEARCH.....	49
TECHNOLOGICAL BARRIERS	49
Pelton Turbine.....	50
Tank Size	50
Roundtrip Efficiency.....	51
ECONOMIC BARRIERS	51
REFERENCES	53
APPENDIX.....	55
MATLAB/SIMULINK MODELS.....	55

LIST OF TABLES

Table 1. Truth table for determining which phase of the cycle to perform.

Table 2. Different parameters effect energy and power capacities, as well as cost

Table 3. Parameters used in Grid Operator and Renewable Energy Generation

LIST OF FIGURES

Figure 1. Energy storage can play a vital role in balancing intermittent renewable energy sources.....	2
Figure 2. Traditional CAES configuration uses underground caverns to store compressed air. Natural gas combustion is used during expansion. (CAES Development Company)..	5
Figure 3. Standard pumped hydro storage facility. (TVA).....	7
Figure 4. CF-CAES conceptual schematic	11
Figure 5. Artistic rendition of a complete CF-CAES system	13
Figure 6. Each phase of the cycle has an energy input or output, in the form of either work or heat.	14
Figure 7. The ratio of initial volume of air to the final volume is defined as α , a very important parameter in the performance of the system.	15
Figure 8. The unavoidable destruction of useful energy to heat occurs after the work input to compress the air causes an increase in temperature.....	17
Figure 9. A percent of energy input will always be lost in the form of heat. It can be seen that γ can be known, and therefore controlled, by varying α	19
Figure 10. Each component of the system was modeled independently then connected into a system-wide model.	20
Figure 11. Diagram of compressor model	21
Figure 12. Tank model derived from conservation of mass and ideal gas law.....	23

Figure 13. The state of the tank can be determined through the integration of all variables that are changing in time: mass, volume, pressure, and temperature.	24
Figure 14. Complete system with embedded logic and controller to cycle through the process.....	27
Figure 15. CF-CAES cycle.	28
Figure 16. Energy extraction causes the expansion of air and thus a drop in temperature.	30
Figure 17. After expansion, a fraction of the energy input still remains in the tank.	31
Figure 18. A venting algorithm must be used in order to avoid the venting of all residual pressure remaining in the tank after expansion.....	32
Figure 19. In utilizing the venting algorithm, the initial pressure in the tank is the residual pressure.	33
Figure 20 The quantity of both energy input and output is a function of the amount of water initially stored in the tank, or specifically, α	35
Figure 21. Upper-bound efficiency of the system as a function of α	36
Figure 22. Typical demand curve for a single day. California, July 15, 2007 (Lawrence Berkeley National Lab).....	42
Figure 23. One week simulation. Power input from wind energy, power output controlled to follow the trend of a daily load curve.	43
Figure 24. Multiple tank batch operation used to provide uninterrupted power output. ..	44
Figure 25. Volume of water (as a percent of tank volume) in each of the four tanks. Out of phase relationship allows continual power output.....	45

Figure 26. Pressure status in each of the four tanks. As one tank is discharging and dropping pressure, the others are receiving power input and their pressure is increasing.45

Figure 27. Merchant storage facilities store low-cost, off peak energy and sell it back in times of high demand..... 47

Figure A. 1 Simulink Model of a Four System Batch Operation.....57

Figure A. 2 Single System Model.....58

Figure A. 3 Tank Model.....59

INTRODUCTION

Throughout the world the power generation industry is actively changing in response to several issues including legislation resulting from increased levels of carbon dioxide in the atmosphere, ever-increasing demand and distribution, and re-assessment of the business-as-usual practices set in place decades ago. This industry, while impacting all aspects of the economy, is being forced to adapt to these challenges and innovation is being spurred. It is unlikely that these issues possess one solution, but rather a combination of approaches will be the optimal method. Installed wind power capacity in the United States is currently at 8,500 MW and is seeing continued growth; likewise, solar power installations are outpacing expectations. The renewable energy industry is currently one of the fastest growing industries in the world.

As wind and solar-based electrical generation continues to increase, the problems inherent with integrating these intermittent sources to the grid increase as well. Some utilities (both domestic and international) are already seeing the impact that intermittent and uncontrollable supply can have on grid control. Traditionally, the utility has had full control of the supply and little control of the demand. After decades of this model, grid operators can accurately forecast load predictions and allow their supply to respond accordingly. When renewable penetration reaches high levels, more and more issues concerning their variability are noticed:

- sudden wind ramps (up or down)
- gust-induced turbine shutdown
- out-of-phase relation between peak demand and peak supply

These characteristics of renewable power production increase the difficulty of integration when combined with their intermittency, and energy storage can contribute to the solution of the energy balancing problem, as shown in Figure 1.

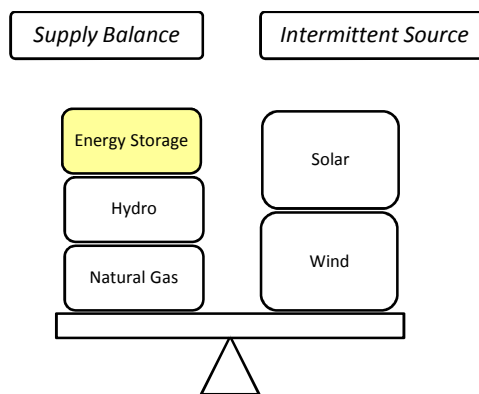

Figure 1. Energy storage can play a vital role in balancing intermittent renewable energy sources.

The US Department of Energy described its goal of supplying 20% of the nation's electricity with wind by the year 2030 in a report issued in 2008 [1]. That report concludes that this level of penetration will be made possible by expanding load balancing areas, creating more flexible electric transmission and using natural gas generators to balance the remaining variability. However, significant barriers exist to these approaches: there are regulatory hurdles involved with expanding load balancing areas; grid expansion faces financial and permitting obstacles, as well as significant

public opposition; and there are definite, long term environmental and financial risks associated with fossil fuels such as natural gas. These methods to counterbalance the high wind power penetration into the national electric grid are viable and will be implemented, but there is an additional technology that can be investigated to counteract the problematic interaction of wind power and other renewables: energy storage.

EXISTING ENERGY STORAGE SYSTEMS

Energy storage has been used for years to decouple the time of electricity generation from the time of its use. Short term energy storage has traditionally been used for system regulation and spinning reserve; it has also been used as transmission curtailment in allowing grid operators to overcome transmission bottlenecks [2]. Recently there has been renewed research and interest into various energy storage technologies as a means to make intermittent renewable energy sources dispatchable and controllable. Investigations into the applicability and benefits of response systems (seconds or milliseconds) and bulk systems (minutes and hours) integrated with renewable energy sources has shown the potential for various energy storage technologies [3]. The state of energy storage in the US in 2006 was shown by S. van der Linden to be at a critical time for advancement and integration: “The current storage concepts are ready for deployment... storage needs to be implemented.” [3]

Traditional Compressed Air Energy Storage

Compressed Air Energy Storage (CAES) is a proven technology with two successfully facilities operating in the world (Huntorf, Germany and McIntosh, Alabama). Cavallo notes that “...with an installed capital cost of about \$890/kW, CAES is the least cost utility scale bulk storage system available” [4]. However, the means of extracting energy from the compressed air storage still requires the use of natural gas.

The sudden expansion of air through a turbine in the CAES scheme causes a dramatic temperature drop, thus necessitating the addition of heat, often in the form of natural gas combustion. While using roughly 2/3 to 1/2 less fuel less than a conventional natural gas/combined cycle power plant, traditional CAES systems still require combustion to bring the compressed air to an appropriate temperature.

The standard configuration for a traditional CAES system can be seen in Figure 2. It is a competitive means of storing energy as it has nearly the lowest capital cost per unit energy of any modern energy storage technologies [14].

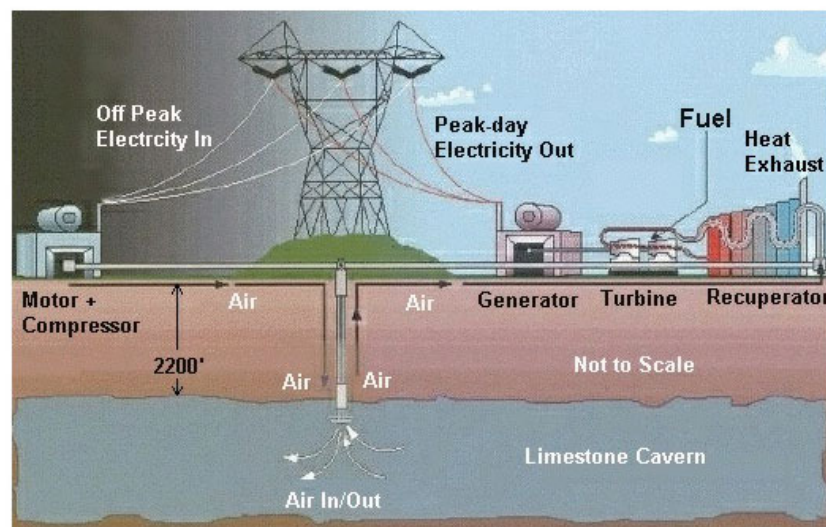

Figure 2. Traditional CAES configuration uses underground caverns to store compressed air. Natural gas combustion is used during expansion. (CAES Development Company)

There have been advances in traditional CAES cycle design, attempting to decrease or eliminate the use of natural gas. The possibility of using thermal energy storage in a CAES cycle was investigated by Bullough, et al. [5]. In this configuration,

the heat generated during the compression phase is transferred to a thermal storage medium. The heat is stored, and then exchanged with the air prior to the expansion phase reheating it to an acceptable temperature for expansion.

Traditional CAES systems use low-cost off peak energy to operate air compressors, storing energy as compressed air. In 1982 Ramakumar [6] proposed the idea of using wind energy to compress air for energy storage. The idea to use wind to operate an air compressor has been continually investigated since. Lieberman, Enis and Rubin discussed the operation and grid-connection of a hybrid wind energy/compressed air facility [7]. They looked at operating the compressor both electrically and mechanically either in the nacelle or on the ground. In addition, they investigated a novel approach to integrate storage with transmission: mile long sections of 2.5 feet diameter pipes where both the compressed air is stored and the energy is transmitted. A similar concept is being commercially developed by Massachusetts-based General Compression, Inc.

In their Energy Storage Handbook, the Electric Power Research Institute (EPRI) reviews CAES plants and looks at the services such facilities can offer to the grid [9]. In their report, they conclude that ‘small CAES’ systems (10 MW or less) would be particularly well suited for load shifting up to 3 hours. In the EPRI supplement for Wind Energy, they conclude that 10 MW CAES is well suited for transmission curtailment, time shifting and forecast hedging [10].

Pumped Hydro

Pumped hydro storage facilities exist all over the world. The typical operation is to use low cost electricity during off peak hours to pump water into an elevated reservoir. When demand requires electricity, the flow is reversed and discharged through a turbine. This allows energy to be stored in the form of potential energy in the elevated water, then recovered through a traditional hydroturbine. Figure 3 is an illustration of such a system in Tennessee.

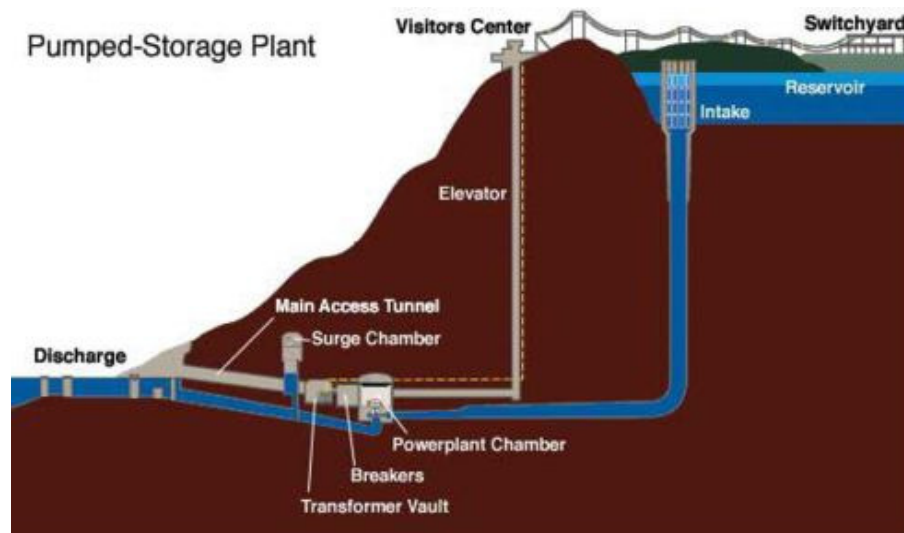

Figure 3. Standard pumped hydro storage facility. (TVA)

While these systems can effectively store large quantities of energy, they are inherently site specific. For this type of energy storage, a significant elevation gain is required. The typical locations are on top of hills near acceptable waterways. Ideally they are near existing dams and hydroturbines.

As well as using wind energy to compress air and store energy, it has been investigated how wind energy might be used to pump water and store energy in the form of potential energy in the water. In 2004 Castronuovo and Lopes showed the use of a low and high water reservoir for wind to pumped-hydro storage [8]. The wind energy is used to pump water to the high reservoir in times of low demand; then when needed, the water is run through a hydroelectric turbine into the low reservoir.

Batteries, Fuel Cells & Flywheels

There has been an extensive amount of research and commercialization performed on various other energy storage systems. These other systems consist of various batteries, fuel cells, flywheels, etc. and are characterized as response systems (providing power for seconds or milliseconds).

- *Sodium Sulfur (NaS) Batteries:* uses a liquid sulfur and salt battery reaction to store excess energy. Batteries using this technology have been used to supply energy to the grid, notably in Japan
- *Flow Batteries:* generate energy as chemicals stored in tanks are allowed to mix. They can be easily recharged but are relatively expensive to operate.
- *Lithium-ion Batteries:* one of the highest energy density battery formulations and also one of the lightest has found application in portable and automotive applications. Cost would be a big issue for non-portable storage applications associated with the grid where the other advantages like low weight are not as compelling.

- *Lead Acid Batteries:* are the oldest battery storage technology and also widest spread. In comparison, they suffer from low energy density and high environmental impact.
- *Fuel Cells:* have the advantage of being rechargeable by just adding new chemical fuel. They have the disadvantage of being expensive to build (in comparison).
- *Flywheels:* store energy in the kinetic energy of massive spinning wheels. The energy is extracted directly to drive generators and produce electricity.

Applications have been found on smaller scales like uninterruptible power supplies for individual buildings; efforts are being made to scale flywheel technology to sizes required by grid operators.

PROPOSED ENERGY STORAGE SYSTEMS

The goal of this research is to develop a feasible system that is capable of meeting the challenges of grid-integration posed by renewable energy sources. From daily to within-the-hour storage, this system will be able to mitigate ancillary service demands and provide peak-load shifting capabilities to the grid operators. This technology takes the most attractive attributes from CAES and pumped hydro storage and eliminates some of their shortcomings. Its similarity to CAES comes with a significant difference: The working fluid used to recover the energy is incompressible. The proposed approach avoids the requirement of additional energy, thus greatly improving the overall performance of the energy storage system.

This study indicates that this system has several potential advantages over current energy storage systems:

- does not require the use of natural gas
- not site-specific
- scalable/adaptable to many different applications
- low capital cost
- simpler system optimization and control based on nozzle velocity (in an impulse turbine);
- better thermal management since the working fluid acts as a heat sink

Carbon-Free Compressed Air Energy Storage

In its most basic manifestation, the Carbon-Free Compressed Air Energy Storage, CF-CAES, System uses two fluids, a compressible and an incompressible fluid. Air and water are the most common examples of each. Energy is stored by pumping the compressible fluid in an enclosed tank or chamber. Unlike the current standard of Compressed Air Energy Storage (CAES), the compressible fluid is not expanded through a turbine; rather it is used to push an incompressible fluid through an impulse or hydro-turbine. As a result, the expansion takes place over the entire volume of compressed gas, not just the small amount passing through a nozzle. The storage tank then has time to equilibrate with the surrounding environment and no additional heat is needed to counteract the problematic temperature drop that accompanies sudden air expansion in a turbine.

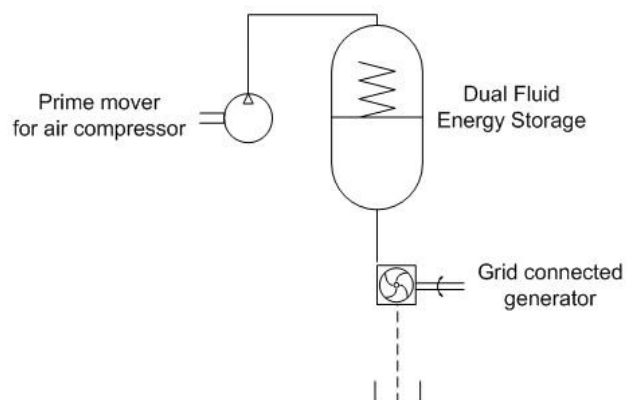

Figure 4. CF-CAES conceptual schematic

A conceptual sketch of the CF-CAES system is shown in Figure 4. In this scenario, wind or solar energy is used to compress air in a ground level tank, either through an in-nacelle compressor or by electrically powering a ground-level compressor. The compressed air is used to charge water stored in a pressure vessel. Once charged, the compressed air exerts a force on the water. The water drives a hydro-turbine which turns a generator producing electricity. Finally, consumptive use of water can be avoided by capturing the water after it has moved through the turbine and reusing it.

The fundamental principle behind this research is the use of two fluids in which a compressible fluid is used as energy storage and an incompressible fluid is used for energy recovery. The configuration shown in Figure 5 utilizes wind energy to compress the air in large tube trailers.

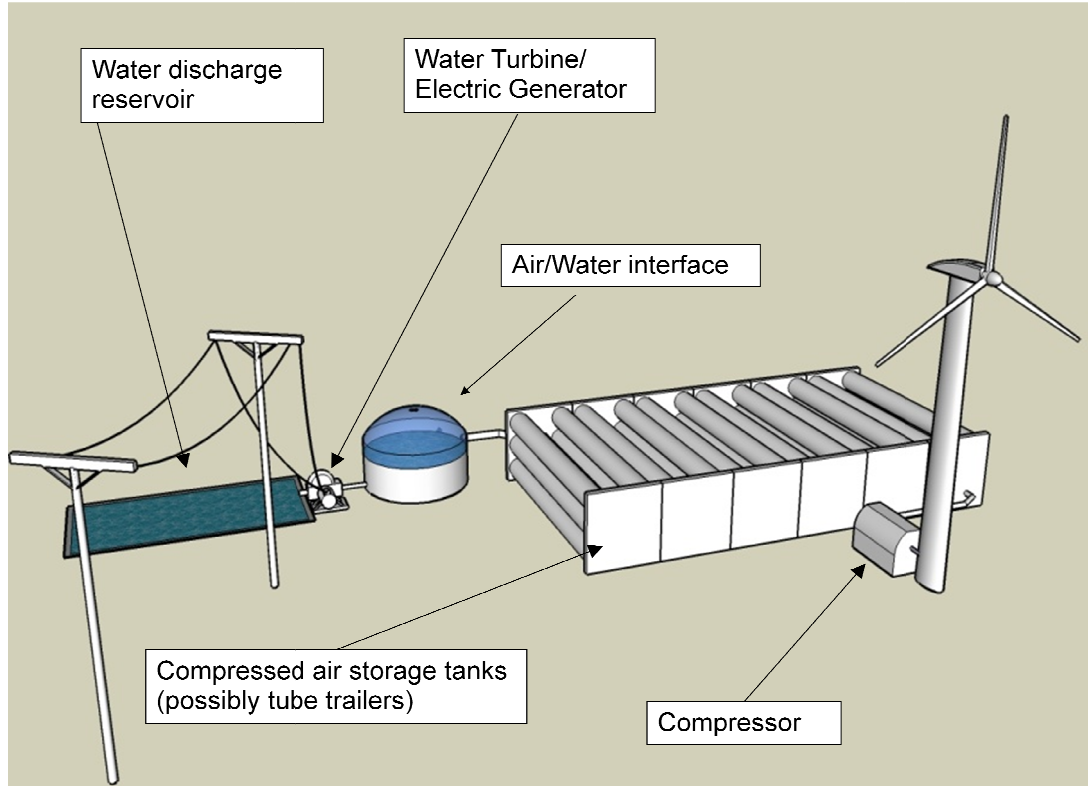

Figure 5. Artistic rendition of a complete CF-CAES system

Finally, it should be pointed out that others have recognized the advantage of a storage approach utilizing multiple fluids and a number of patents have been granted for variations on this theme [10-12] but none have been reduced to practice. In the following sections, the barriers that have limited this concept will be discussed in detail.

THERMODYNAMIC ANALYSIS

Before detailed models of the system's components were developed, a thorough analysis of the energy flows within the cycle was performed. This not only provides information crucial to operation of the system, but certain insight into economic viability as well. A single tank that contains both the compressible and incompressible fluid was used as the system to investigate energy inputs, outputs, and heat transfer. The process of interest is shown below:

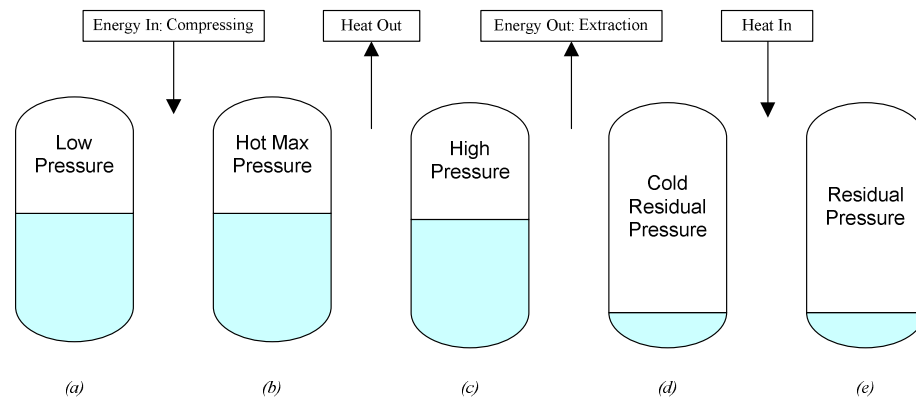

Figure 6. Each phase of the cycle has an energy input or output, in the form of either work or heat.

When mass is added to a fixed volume of air, both pressure and temperature increase. The increase in pressure stores energy in mechanical potential, while the increase in temperature stores energy in the form of heat. How these two factors relate can be determined through first law analyses. In the above process, from (a) to (b), air is being added to the tank, increasing the temperature and pressure of the air. Energy is now

stored in the tank (in mechanical potential as well as heat) and inevitably equilibrates with its surroundings: *(b)* to *(c)*. The reduction in temperature due to heat transfer also reduces the pressure. Energy can be removed from the system by allowing the pressurized air to push the water out of the tank. During this expansion, the volume of air is increasing which causes both temperature and pressure to go down: *(c)* to *(d)*. The cold air in the tank will now draw heat from the surroundings, increasing the temperature and pressure. At this state the tank can then be re-filled with water and the system and cycle from energy input, through storage, to output, with respective heat transfer along the way.

One important parameter of the system is the ratio of air to water in the uncharged tank; to capture this characteristic, the parameter α is defined as the ratio of the initial volume of air to the final volume of air. Low α values correspond to relatively large quantities of water initially in the system. Conversely, high α values describe a system with very little water cycling through it, Figure 7.

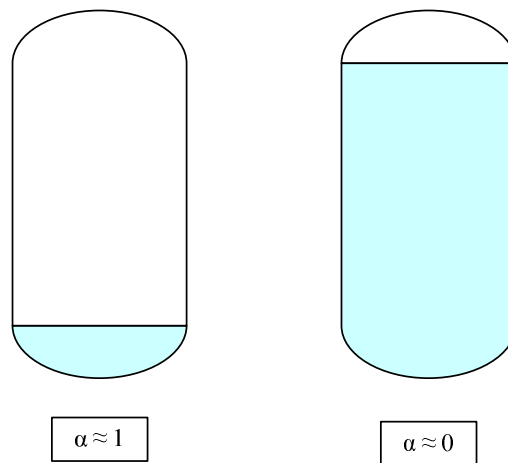

Figure 7. The ratio of initial volume of air to the final volume is defined as α , a very important parameter in the performance of the system.

Regardless of what alpha value is used, once all the water has been removed from the tank, the pressure inside is most likely not at atmospheric pressure. For each α , a particular target pressure does exist to produce this result; however, these cases yield very low energy output and are thus unlikely in any application. Thus, the residual pressure remaining in the tank after the water has been removed and the air has expanded can be calculated from the assumed isentropic expansion of the compressed air:

$$Pv^k = \text{constant}$$

for a constant mass of air, isentropic expansion:

$$PV^k = \text{constant}$$

$$P_1V_1^k = P_2V_2^k$$

Where subscript (1) and (2) refer to the states surrounding the expansion of air and removal of stored energy and k is the ratio of specific heats for air (approx. 1.4). From the definition of α :

$$\alpha = \frac{V_1}{V_2} = \frac{\text{Volume of air prior to expansion}}{\text{Volume of air after expansion}}$$

$$P_2 = P_1\alpha^k$$

for the first state being the high pressure air and the second being the residual:

$$P_{\text{residual}} = P_{\text{high}}\alpha^k$$

Because of this fact that there is a residual pressure in the tank after expansion, an algorithm was developed to allow water to be pumped back into the tank without compressing the air in the process (*Operational Cycle*). Once the tank is filled with water

to the desired alpha ratio, the compressor starts at this pressure and operates until the high pressure is achieved. This initial condition of initial pressure being equal to the residual pressure in the tank after expansion must be taken into consideration during the thermodynamic analysis in order to accurately represent the energy flows in the system. The amount of heat created (and therefore mechanical potential lost) is directly proportional to the pressure difference; hence designing a system to minimize this loss is beneficial. The following derivation develops the relationship between this quantity of heat and total energy input.

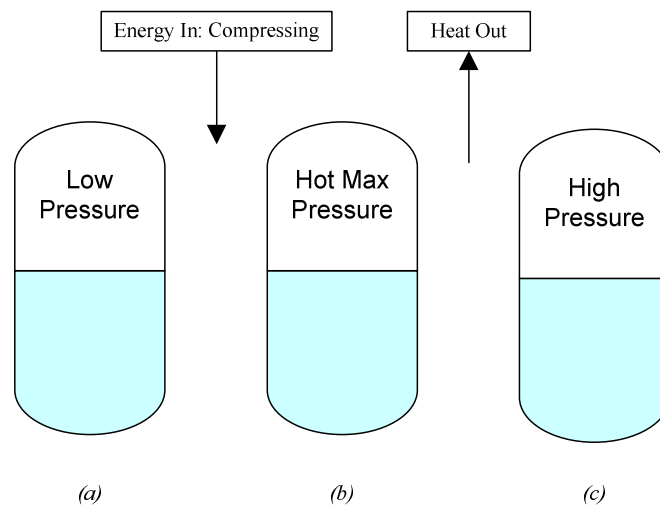

Figure 8. The unavoidable destruction of useful energy to heat occurs after the work input to compress the air causes an increase in temperature.

The work input to the system equals the difference in total internal energy between states *a* and *b* in Figure 8. Once again, assuming an isentropic compression process of the air in the tank:

$$P_a v_a^k = P_b v_b^k$$

$$P_a \frac{V_a^k}{m_a^k} = P_b \frac{V_b^k}{m_b^k}$$

$$T_a m_a^{1-k} = T_b m_b^{1-k} \quad \text{with} \quad V_a = V_b \quad \text{and} \quad P = \frac{mRT}{V}$$

Substituting in the definition for total internal energy,

$$U = mC_v T$$

The total internal energy at state b can be shown to be,

$$U_b = U_a \left(\frac{m_b}{m_a} \right)^k = U_a \alpha^{-k}$$

And the change in total internal energy during the constant volume compression,

$$\Delta U_{a-b} = U_a [\alpha^{-k} - 1]$$

During the next two states in Figure 8, b to c , the mass of air equilibrates with the environment in a constant mass, constant volume heat addition.

The internal energy at state c ,

$$U_c = m_c C_v T_c$$

with,

$$m_c = m_b \quad \text{and} \quad T_c = T_a$$

$$U_c = m_b C_v T_a = U_a \frac{m_b}{m_a} = U_a \alpha^{-1}$$

And the change in total internal energy during the constant mass and volume heat addition,

$$\Delta U_{b-c} = U_a [\alpha^{-k} - \alpha^{-1}]$$

Therefore, the percent of energy input that becomes heat, γ , is the ratio of these two differences:

$$\gamma = \frac{\Delta U_{b-c}}{\Delta U_{a-b}} = \frac{U_a[\alpha^{-k} - \alpha^{-1}]}{U_a[\alpha^{-k} - 1]}$$

$$\gamma = \frac{1 - \alpha^{k-1}}{1 - \alpha^k}$$

The following figure shows γ , the percent of energy input that is lost to heat, as function of α . At low values the pressure difference between the residual pressure at the end of the cycle and the target pressure is very high, and therefore a larger percentage of input is transformed into heat. This quantity can be shown to converge to $k-1/k$ as α approaches 1. For air, at best, 28.6% of energy input will be lost in the form of heat.

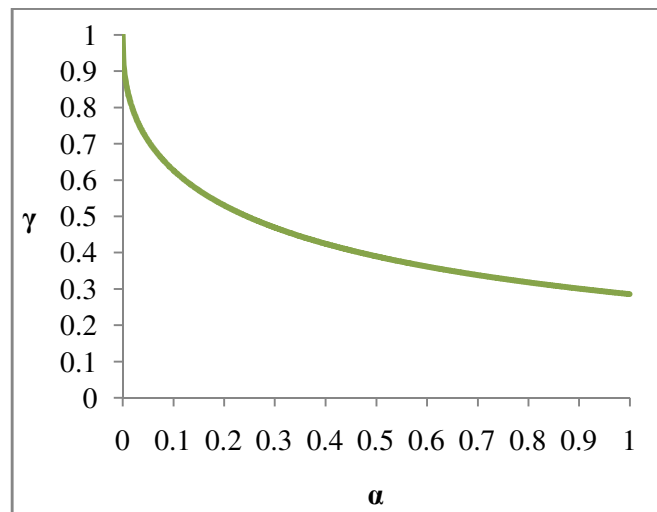

Figure 9. A percent of energy input will always be lost in the form of heat. It can be seen that γ can be known, and therefore controlled, by varying α .

The thermodynamic analysis aids in determining feasibility of the system as well as producing directions for design.

MODELING

Detailed dynamic models were created in order to determine system-wide operation and performance characteristics. Each component of the system was modeled then assembled with their interactions represented within the model. Acting over the entire system is the control system with embedded logic triggers particular to a desired application.

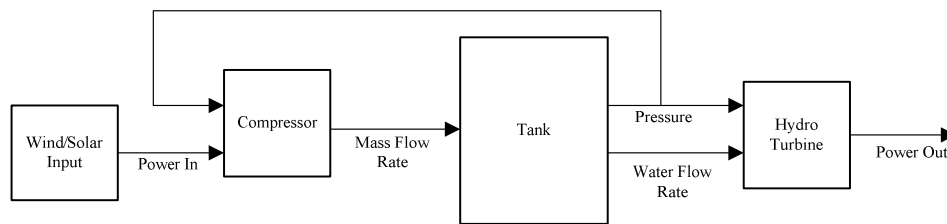

Figure 10. Each component of the system was modeled independently then connected into a system-wide model.

Compressor

There are many different compressor designs, from centrifugal to positive-displacement, most receiving their power input through an electric motor. For this energy storage system, it is possible to have wind power as an input, in which case a mechanically driven, in-nacelle compressor could be investigated. However, for this research, a compressor receiving electrical power input was assumed.

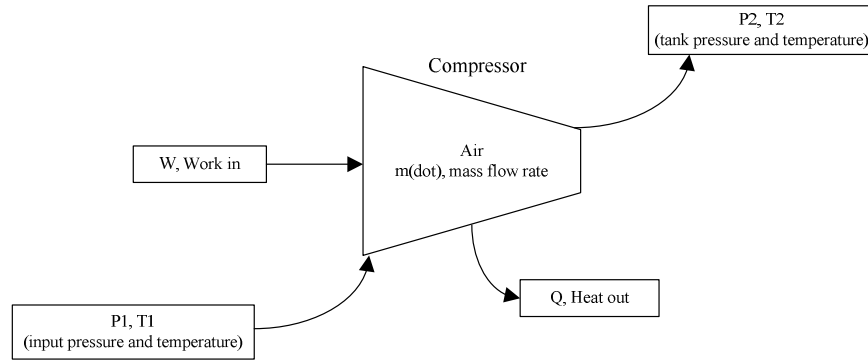

Figure 11. Diagram of compressor model

The compressor in this system is used to add mass to a rigid tank, increasing the pressure in the tank. Additionally, since the compressor will be receiving input from an external source (solar array, wind farm, etc.), the power input was considered a known quantity. It was therefore desired to determine the mass flow rate through the compressor, given the work input and states (pressure and volume) of the tank. The work input (per unit mass) is equal to the integration of specific volume over the pressure change.

$$\frac{W}{m} = \int_{P_1}^{P_2} v \, dP, \quad W = m \int_{P_1}^{P_2} v \, dP$$

As the goal of this model is to determine mass flow rate through the compressor given pressure in the tank and work input, an assumption is made concerning the process of compression. Assuming a polytropic compression process with polytropic coefficient equal to the ratio of specific heats, k (C_p/C_v), the process is thus isentropic; substituting into the above equation gives:

$$Pv^k = \text{constant}, C, \quad v = \left(\frac{C}{P}\right)^{\frac{1}{k}}$$

$$W = m \int_{P_1}^{P_2} \left(\frac{C}{P}\right)^{\frac{1}{k}} dP$$

The above equation describes the work required to compress a mass, m , from pressure P_1 to P_2 .

Differentiating both sides with respect to time:

$$\frac{dW}{dt} = \frac{d}{dt} \left(m \int_{P_1}^{P_2} \left(\frac{C}{P}\right)^{\frac{1}{k}} dP \right) = \frac{dm}{dt} \int_{P_1}^{P_2} \left(\frac{C}{P}\right)^{\frac{1}{k}} dP + m \frac{d}{dt} \left(\int_{P_1}^{P_2} \left(\frac{C}{P}\right)^{\frac{1}{k}} dP \right)$$

(note: the pressure in the tank, P_2 , and the mass of air in the tank, m , are both functions of time). Evaluating the integrals then taking derivatives and rearranging:

$$\frac{dW}{dt} = \frac{dm}{dt} C^{\frac{1}{k}} \left[\frac{k}{k-1} \left(P_2^{\frac{k-1}{k}} - P_1^{\frac{k-1}{k}} \right) + m P_2^{-\frac{1}{k}} \frac{dP_2}{dm} \right]$$

$$\frac{dm}{dt} = \frac{dW}{dt} C^{-\frac{1}{k}} \left[P_2^{\frac{k-1}{k}} \left(\frac{k}{k-1} + 1 \right) - P_1^{\frac{k-1}{k}} \frac{k}{k-1} \right]^{-1}$$

This equation was used to model the ideal thermodynamic relationship of the compressor; the mass flow rate through the compressor can now be determined for a given volume, tank pressure and power input.

Tank

Throughout the cycle of the system, the pressure, temperature, and mass (both air and water) within the tank are constantly changing. It was assumed that even under the expected pressure in the tank, water would be modeled as completely incompressible. Therefore, any incremental change in volume of water leads to the same change in volume of the air. While it is acknowledged that some of the air will be forced into

solution with the water, this phenomenon is assumed to have negligible impact and is outside the scope of this effort.

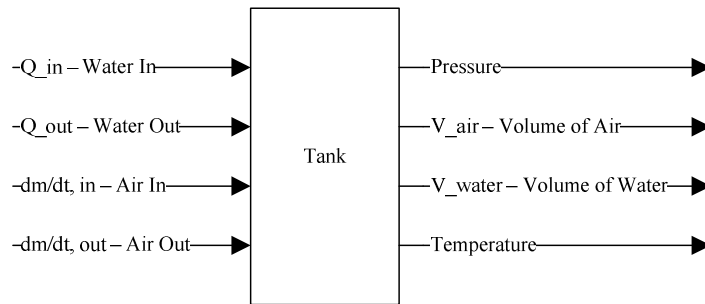

Figure 12. Tank model derived from conservation of mass and ideal gas law.

In a control volume analysis with the control volume being the volume of air in the tank, the ideal gas law states:

$$PV = mRT, \quad P = mRTV^{-1}$$

$$\frac{dP}{dt} = \frac{d}{dt} (mRTV^{-1}) = \frac{dm}{dt} \frac{RT}{V} + \frac{dT}{dt} \frac{mR}{V} - \frac{dV}{dt} \frac{mRT}{V^2}$$

The rate of the change of the pressure within the tank is a function of the mass, temperature and volume of the air on the tank, which are all changing in time. The mass and volume are functions of the cycle – whether the system is charging or discharging. The temperature is determined from the assumed polytropic compression and expansion.

$$Pv^k = \text{constant}$$

$$P \left(\frac{V}{m} \right)^k = P \left(\frac{RT}{P} \right)^k = \text{constant}$$

differentiating both sides with respect to time:

$$\frac{d}{dt} \left[P \left(\frac{RT}{P} \right)^k = \text{constant} \right] = \frac{d}{dt} [P^{1-k} T^k = \text{constant}]$$

$$(1 - k)P^{-k} \frac{dP}{dt} T^k + kP^{1-k} \frac{dT}{dt} T^{k-1} = 0$$

simplifying,

$$\frac{dT}{dt} = \frac{T}{P} \frac{dP}{dt} \left(\frac{k-1}{k} \right)$$

As air or water is added or removed from the tank, the subsequent changes in temperature and pressure can now be determined. This relationship is implemented inside the above tank subsystem as shown below.

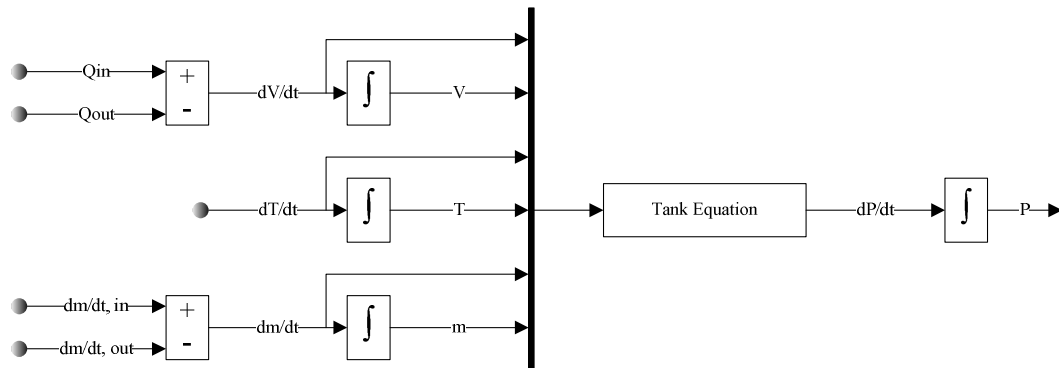

Figure 13. The state of the tank can be determined through the integration of all variables that are changing in time: mass, volume, pressure, and temperature.

Turbine

When power is desired from the system, water can be removed through an adjustable diameter nozzle and delivered through a hydro turbine. Accurately modeling the interaction of the fluid with the turbine requires extensive computational abilities. The performance of particular hydro turbines, such as a pelton wheel, has been documented

through detailed experimentation and can effectively approximate the performance of the turbine by scaling the quantifiable power of the stream passing through the nozzle:

$$\dot{W}_{stream} = Q\Delta P$$

$$\dot{W}_{pelton} = \eta_{pelton}\dot{W}_{stream} = \eta_{pelton}Q\Delta P$$

Hence, for this analysis, all dynamic and hydrodynamic effects of the turbine were assumed to be captured in the above efficiency term.

Neglecting the minor losses and hydrostatic pressure term and assuming that the turbine discharges to atmospheric pressure, the flowrate can be determined by:

$$Q = \frac{\dot{W}_{pelton}}{\eta_{pelton}(P_2 - P_{atm})}$$

In the above expression, \dot{W}_{pelton} is the power output desired from the turbine; the nozzle diameter can then be adjusted such that the calculated flowrate will be achieved and the desired power will be output.

Logic

The control system that governs the performance of the system was created using decision matrix (truth table) criteria. To accurately model the behavior of the system through time, the logic controller must step the system through the actual actions of the cycle. This is analogous to actual circuitry that would be controlling valves, pumps, switches, etc. Preliminary values were decided for compression pressure, tank volume, and alpha; the logic then needs to compare actual pressure and volume of water in the tank with these cutoff values and determine the decision to be performed. The sequence

of events that the system cycles through is described in detail *Operational Cycle*. The Truth and Action Tables can be seen below. The action is determined from the Condition Table on the left and read down the column as follows: if P is not greater than P_i and P does not equal P_{high} and P is greater than P_{high} and V is greater than the product of alpha and V_{tank} , etc. then perform the action at row 1 of the Action Table (*Fill*).

Table 1. Truth table for determining which phase of the cycle to perform.

Condition	D1	D2	D3	D4	Row	Description	Action
$P > P_i$	F	-	T	-	1	<i>Fill</i>	Fill = 1;
$P \geq P_i$	-	T	T	-			Press = 0;
$P = P_{high}$	F	-	-	-			Extract = 0;
$P < P_{high}$	T	T	-	-	2	<i>Pressurize</i>	Fill = 0;
$P \leq P_{high}$	-	-	T	-			Press = 1;
$V > \alpha V_{tank}$	T	F	-	-			Extract = 0;
$V \geq \alpha V_{tank}$	T	T	T	-	3	<i>Extract</i>	Fill = 0;
$V = \alpha V_{tank}$	F	T	-	-			Press = 0;
$V < V_{tank}$	-	T	-	-			Extract = 1;
$V = V_{tank}$	-	F	-	-	4	<i>Nothing</i>	Fill = 0;
$V \leq V_{tank}$	T	-	T	-			Press = 0;
Action: Specify a row from Action Table	1	2	3	4			Extract = 0;

System

All of the components and control logic were then assembled into a complete system. This model, shown below, will now cycle through the operation of the system with accurate mechanical, thermodynamic, and conservation principals. The operation of each component (pump, compressor, turbine, valves) produces a subsequent change in the state of the tank. These states are determined through the integration of the differential equation governing the tank. This state is monitored by the logic criteria and a decision is sent to the controller.

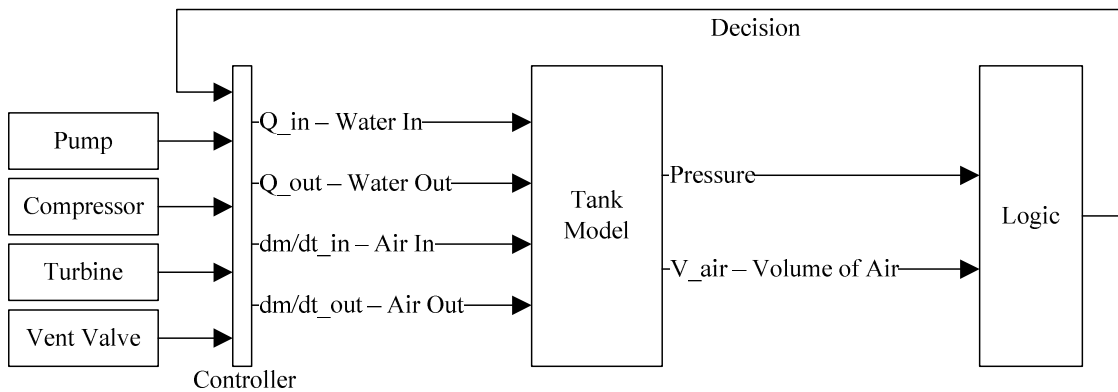

Figure 14. Complete system with embedded logic and controller to cycle through the process.

OPERATIONAL CYCLE

There are a variety of ways in which this energy storage system can behave. Due to the nature of the proposed system, continuous operation is not possible, therefore, a cyclic batch process is proposed. A possible sequence is shown below: fill the tank with water to the level dictated by the desired alpha, compress the air above the water, extract energy by releasing the water through the turbine, vent the residual pressure to another tank or the atmosphere then re-fill the tank. There are many different possibilities of not only performing events in parallel and series (compressing air while extracting water) but modified thermodynamic cycles as well (different venting algorithms).

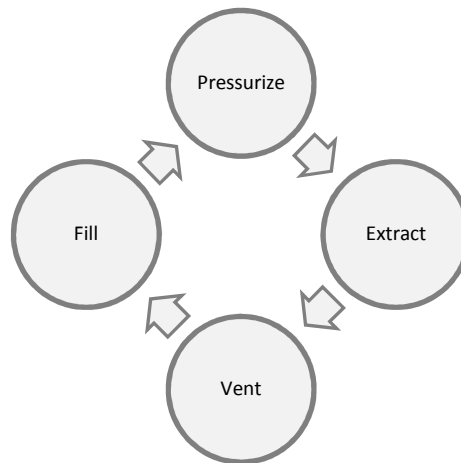

Figure 15. CF-CAES cycle.

Pressurize

Beginning with the state where the tank contains a particular amount of water, the compressor is allowed to operate and increase the pressure of the air above the water. The volume of air can be ducted to another storage vessel or a series of tube trailers.

Whatever the configuration, the chosen value of alpha can still be obtained, even though multiple tanks might exist.

Extract

Once the air pressure meets the target value, energy can be stored until needed. The time that the system will store the energy before dispatching it to the grid is dependent on the application. When power is demanded, water is released through the hydro turbine (impulse, Pelton style) which drives a generator, creating electric energy. The power output of the hydro turbine can be controlled through use a variable diameter nozzle; this provides a range of power outputs. For example, as the water is released and the air pressure in the tank decreases, the nozzle can respond in such a way as to provide a constant power output throughout the extraction.

Loop

As was discussed earlier, once the tank is empty of water, it is most likely not at atmospheric pressure, and therefore a significant amount of stored energy still remains. In order for the cycle to loop, water needs to be added back into the tank. Water cannot be pumped back into the tank when the air is under such high pressure without further design considerations. Likewise, it is not desirable to vent the residual pressure to

atmospheric, as there is still a substantial amount of energy stored in the system. Using the state analysis for internal energy that was previously used in *Thermodynamic Analysis*, the percent of stored energy that is remaining in the tank after expansion (*c* to *d* below) can be derived:

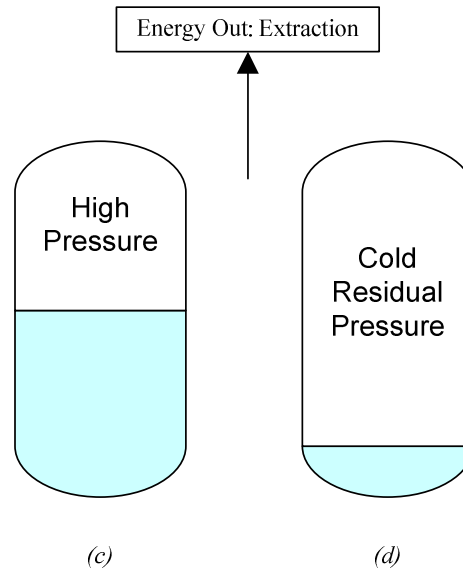

Figure 16. Energy extraction causes the expansion of air and thus a drop in temperature.

The internal energy at state *c* as a function of the initial internal energy,

$$U_c = U_a \alpha^{-1}$$

And at state *d*,

$$U_d = U_a \alpha^{k-2}$$

The percent of stored energy remaining in tank after expansion, ε , is the ratio of these two energies,

$$\varepsilon = \frac{U_d}{U_c} = \frac{U_a \alpha^{k-2}}{U_a \alpha^{-1}} = \frac{\alpha^{k-2}}{\alpha^{-1}} = \alpha^{k-2}$$

This relationship can be seen in the following figure.

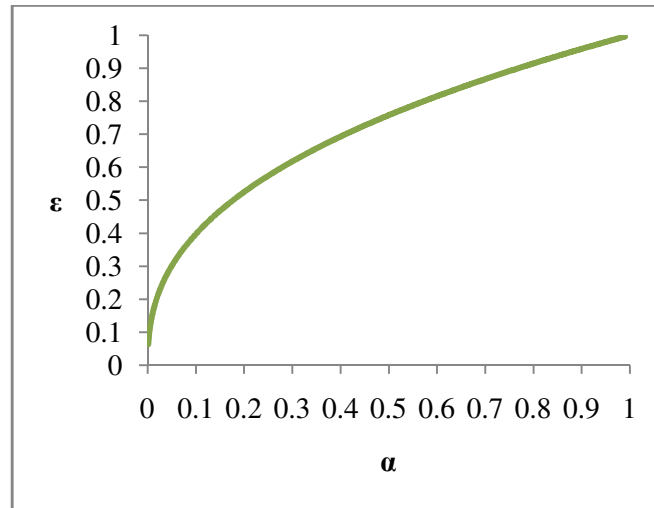

Figure 17. After expansion, a fraction of the energy input still remains in the tank.

A venting algorithm was developed to address this issue of residual pressure and stored energy remaining in the tank after extraction, Figure 18. In this procedure, a second tank nearly equal in size to the volume of water is used to collect the water during discharge. Once extraction is complete, the two tank pressures are equilibrated. Given that the second tank contains very little air, the residual pressure remains essentially unaffected. An unbiased pressure difference now exists between the tanks and water can be pumped from one to the other. The end result of this algorithm is the original tank filled with water and containing the residual air pressure; the second tank contains just air, also at the residual pressure. The second tank is then either vented or used in a secondary process. If vented, stored energy is still being lost, but just a fraction of the amount remaining in the tank. During the next cycle, the original tank is no longer being

pressurized from atmospheric to a particular target pressure, but beginning at the residual pressure.

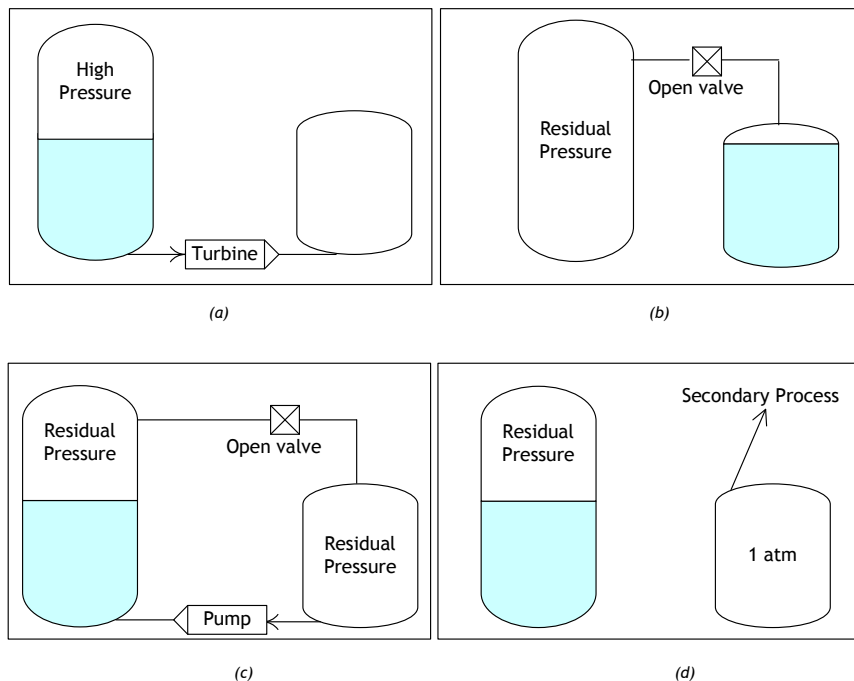

Figure 18. A venting algorithm must be used in order to avoid the venting of all residual pressure remaining in the tank after expansion.

An advantage of this venting algorithm is that the tank begins the next cycle with the air compressed to the residual pressure. In this case the system is cycling between the high and residual pressure, never requiring atmospheric venting. As was previously discussed, α determines both the energy input and how much useful energy can be extracted.

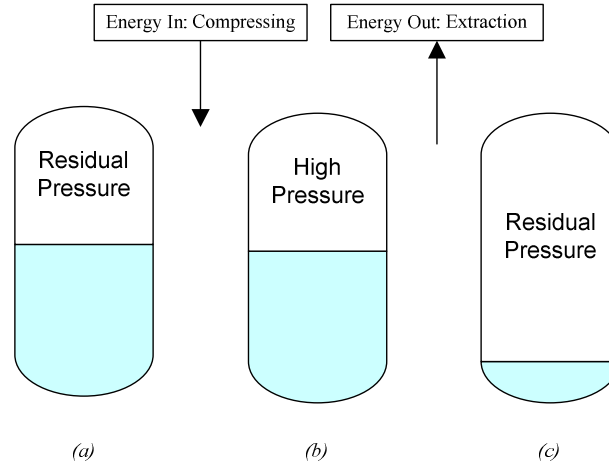

Figure 19. In utilizing the venting algorithm, the initial pressure in the tank is the residual pressure.

The energy output from the system can be determined from the change in internal energy during expansion (b) to (c) in Figure 19:

$$W_{out} = U_c - U_b = m_c C_v T_c - m_b C_v T_b$$

$$W_{out} = \frac{C_v}{R} (P_c V_c - P_b V_b) = \frac{C_v}{R} (\alpha P_c V_b - P_b V_b) = \frac{C_v}{R} (\alpha P_c V_b - \alpha^k P_a V_b)$$

$$W_{out} = \frac{C_v}{R} P_c V_b (\alpha - \alpha^k)$$

Similarly, the energy input to the system utilizing the venting algorithm to keep the initial pressure in the tank at residual pressure is derived by integrating the specific volume over the change in pressure:

$$\frac{W}{m} = \int_{P_a}^{P_b} v dP, \quad W = m \int_{P_a}^{P_b} v dP$$

once again assuming a polytropic compression:

$$Pv^k = \text{constant}$$

and that the initial pressure in the tank is equal to the residual pressure:

$$P_{residual} = P_{high}\alpha^k$$

$$P_a = P_b = P_c\alpha^k$$

substituting these relationships and integrating, the work input to the system assuming the described venting algorithm, as a function of α is:

$$W_{in} = \frac{C_v}{R} P_b V_a \left(\alpha - \alpha^{\frac{k}{k-1}} \right)$$

For an α value close to 0 (little air initially in system), the pressure drops too quickly while the air expands over the large distance to extract any significant amount of energy. Similarly, for high α (little water initially in system) there is too little distance for the compressed air to expand over and all the water is expelled before the air fully expands; also extracting very little energy. Similarly, since the system starts the cycle with residual pressure in the tank, at α values close to 1 and 0, the amount of energy input to the system goes to zero. Figure 20 shows this relationship.

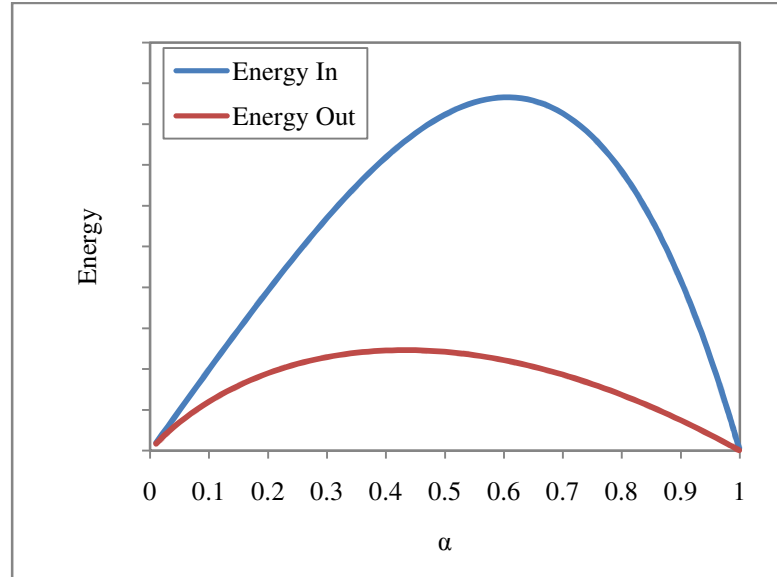

Figure 20 The quantity of both energy input and output is a function of the amount of water initially stored in the tank, or specifically, α .

As the energy input and output are functions of α , the efficiency of a system acting under this venting algorithm is as well. Assuming adiabatic heat recuperation during compression/expansion, and ideal component performance, the inefficiencies of the system are a result of venting losses only. This efficiency, η , of the venting algorithm can be determined from the ratio of energy output and input terms.

$$\eta = \frac{W_{out}}{W_{in}} = \frac{\frac{C_v}{R} P_c V_b (\alpha - \alpha^k)}{\frac{C_v}{R} P_b V_a (\alpha - \alpha^{\frac{k}{k-1}})}$$

$$\eta = \frac{\alpha - \alpha^k}{\alpha - \alpha^{\frac{k}{k-1}}}$$

Under these assumptions, an upper-bound efficiency can be calculated, Figure 21.

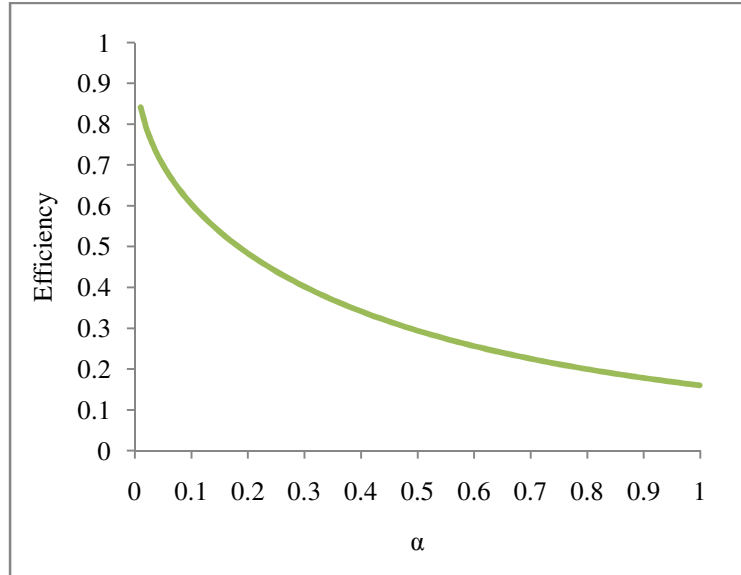

Figure 21. Upper-bound efficiency of the system as a function of α .

Fill

For the cycle to begin again, the tank must be filled with water to a particular height. As was previously shown, this ratio of water to air is a very important parameter in the performance of the system. The amount of water that the tank should initially hold is not necessarily an optimization problem, but a design consideration pertaining to the particular application. In this step, water is pumped into a vented tank such that air is not being compressed in the process.

PARAMETERS

The thermodynamic analysis and dynamic modeling of the system and its components has provided a means to investigate the performance of the system under various conditions. The quantities that govern the effectiveness of this energy storage system are: energy capacity, power capacity, and duration of storage. There are parameters that affect these characteristics, as well as the cost of the system. Energy capacity is a function of both compression pressure and tank volume; these are referred to as cost variables. For a given compressor and turbine, the cost of the system (the tank) scales directly with the size and wall thickness of the pressure vessel. Power capacity is also a function of the cost variable pressure, but not volume. The parameter ‘alpha’ is designated as a performance variable because its value directly influences energy capacity but does not contribute to cost.

Table 2. Different parameters effect energy and power capacities, as well as cost

Parameters	Influencing Factors			<i>Variable Type</i>
	<i>Cost</i>	<i>Energy</i>	<i>Power</i>	
Target Pressure	x	x	x	Cost
Tank Volume	x	x	-	Cost
Alpha	-	x	-	Performance

OPERATION

Through use of the dynamic model, a simulation of the system can operate under various inputs and desired outputs. Tank size and operating pressures can be adjusted and their effect on the performance investigated. For the standard configuration, each step of the cycle that was previously discussed is necessary during operation.

One desired performance metric for this system is adequate lead time notification to the grid operator. With different parts of the country operating under different power scheduling times (15 minutes up to 1 hour), it was desirable for this system to provide such predictability. By monitoring the level of compression in the CF-CAES System, the operator can accurately predict how long it will take for the system to go online at a certain power level. Additionally, if that power level is maintained, appropriate notification could be made to the grid operator concerning when the system will be going offline.

Batch Operation

With a single tank system there will always be a discontinuity in power output as a result of the system cycling through its loop: eventually the tank will run out of water. Some applications may desire an uninterrupted power output from the system; this can be accomplished through a multiple tank system. As one tank is charging (drawing power) the other is discharging (providing power); the two can be sized appropriately to provide a necessary out-of-phase relationship and have a continual power output achieved.

However, because of the expected flowrates both into the tank (pumping phase) and out of the tank (power output phase), the time scales for drawing power and providing power are not necessarily evenly matched. This irregularity would lead to times when both tanks are pumping and not providing power. A third (or more) tanks could be added to the system to balance this timing issue. Examples of multiple tank batch operation can be seen in the following section.

APPLICATION STUDIES

This energy storage system is design to be adaptable to many different scenarios and applications. Potential customers include grid operators, renewable energy electric generation operators and merchant storage facilities.

Grid operators are tasked with balancing generation and load. They generally have no control over the load (demand side), but have been able to control the generation side by increasing or decreasing fuel consumption. With the addition of intermittent generators, the act of balancing becomes more difficult. Energy storage systems, such as CF-CAES, can assist in balancing load and generation.

Owners/operators of wind and solar electric generation facilities are potential customers in that energy storage could allow them to sell electricity to the grid when demand is high, rather than only when the wind is blowing or sun is shining. Policies governing electric utilities vary state to state in the US. Many regulatory agencies are considering time-of-use pricing for retail customers. In these markets, it is possible that regulators would allow utilities to pay a higher rate (\$/MWh) for energy that is dispatchable according to demand schedules. This would provide economic incentives for owners/operators of wind and solar generators to purchase energy storage systems, such as CF-CAES.

Finally, merchant storage facilities are potential CF-CAES customers. Merchant storage facilities take advantage of fluctuations in the energy markets, purchasing energy when demand is low, storing it, and selling it when demand is high. Merchant facilities

currently use a mix of storage technologies, with pumped-hydro being predominant in the western US. The McIntosh CAES plant in Alabama is a merchant facility. Pumped-hydro and CAES both provide low-cost bulk storage technology, but are site specific; CAES also requires burning of natural gas. The proposed CF-CAES is site independent and does not require burning natural gas, making it an attractive option for merchant facilities.

For the following simulations, various power output routines can be maintained to meet the above described application:

- output to follow a daily load curve (grid operators)
- constant power output (renewable energy electricity generation operators)
- daily scheduled power output, such as to meet peak demand (merchant storage facilities).

Grid Operators

For the first two simulations, wind data from a site in southern Idaho was used to develop the input profile for the compressor. The number of tanks and sizes were chosen from OEM information. The parameters of the simulation can be seen below. The value of α was chosen from the modeling information to balance the increased efficiency at lower alphas with the decreased energy output.

Table 3. Parameters used in Grid Operator and Renewable Energy Generation simulations.

CF-CAES Parameters	
No. tube trailers	10
Tank pressure	2850 psi
Total volume	4,379 m ³ – NTP (26.3 m ³ – water volume)
α	0.25
Wind Turbine Parameters	
No. Turbines	13
Type	GE 1.5MW

The goal of utilizing energy storage for a grid operator is to take an intermittent source and provide a predictable, dispatchable output.

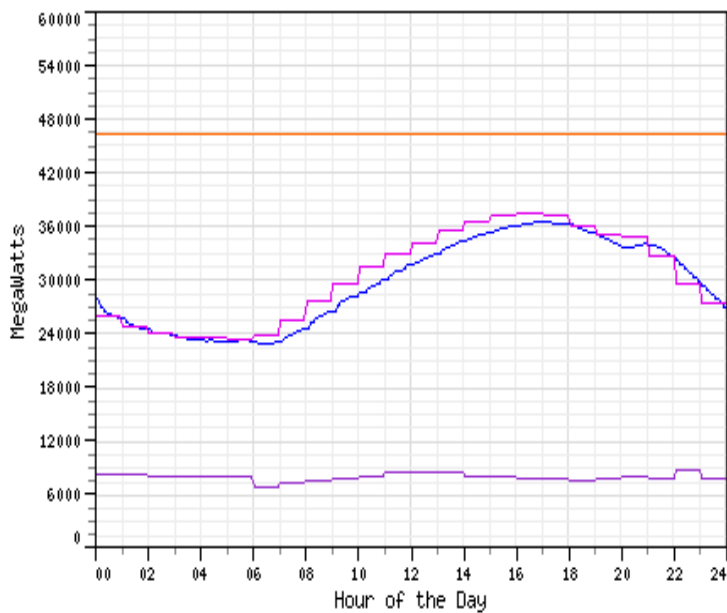

Figure 22. Typical demand curve for a single day. California, July 15, 2007 (Lawrence Berkeley National Lab)

A typical demand curve can be seen above in Figure 22; the line at the top of the figure is power capacity of the system, the bottom line is imported power, the stepped line is the forecast of the smooth actual load curve in blue. Grid operators are tasked with balancing the load with the supply from the utility. Thus, the objective of this simulation was to provide a power output from the CF-CAES system to follow this daily trend, which is modeled as a sine function with a period of one day, the maximum occurring at 3:00pm. The results from this simulation can be seen in the following figure.

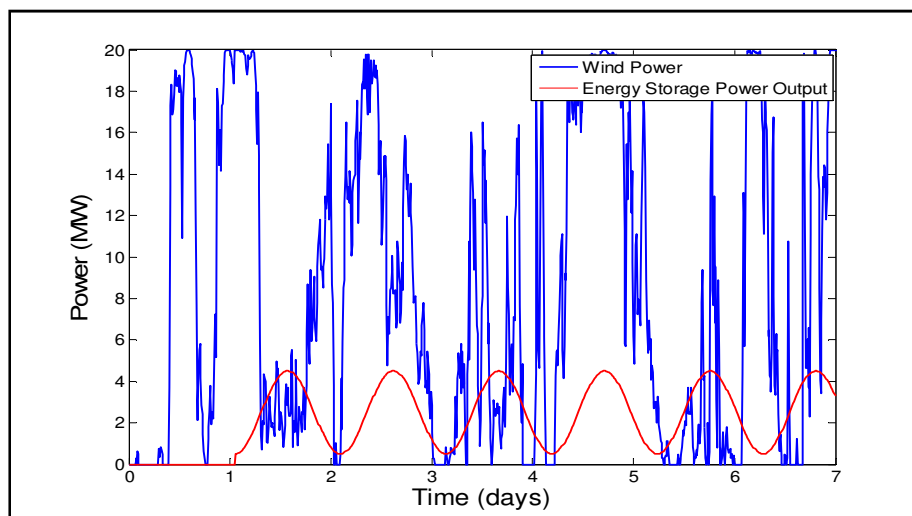

Figure 23. One week simulation. Power input from wind energy, power output controlled to follow the trend of a daily load curve.

Throughout this one-week simulation, the maximum amount of stored energy at a single time was 2.2 MW-h. Throughout the course of the week, 134 MW-h were input, and 88.1 MW-h were output; this results in a roundtrip efficiency of 65.7%.

Renewable Energy Electricity Generation Operator

The desired outcome of this application is to shape the power output from an intermittent wind energy source to the grid. When the wind is blowing, power is being provided to the compressor and energy is being stored in the compressed air. The control system for this simulation mandates that a constant power output be continually provided. This was accomplished through the previously mentioned multiple tank batch operation, each of the four tanks functioning out of phase of one another. The following figures are the results of the simulation. Below, the power output is continually maintained at a constant level.

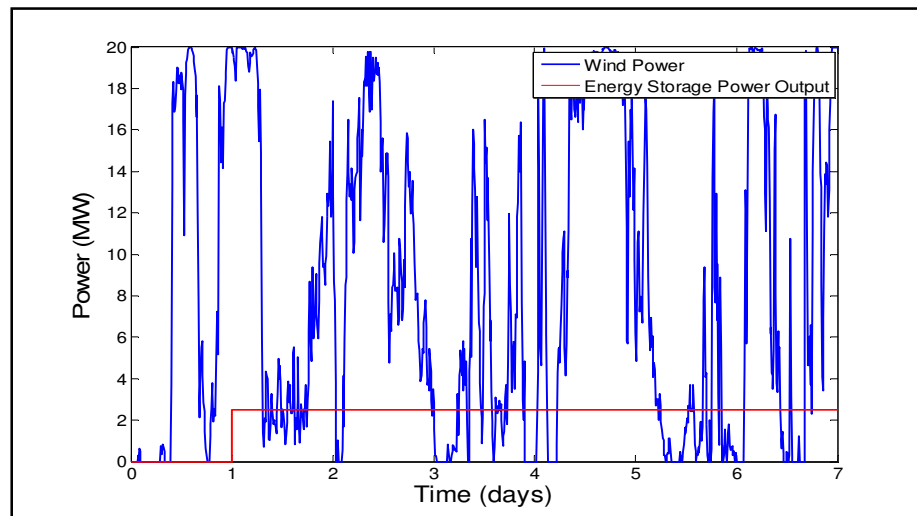

Figure 24. Multiple tank batch operation used to provide uninterrupted power output.

The following two figures show the how the pressure and water volume of the tanks change throughout the course of a day of the one-week simulation.

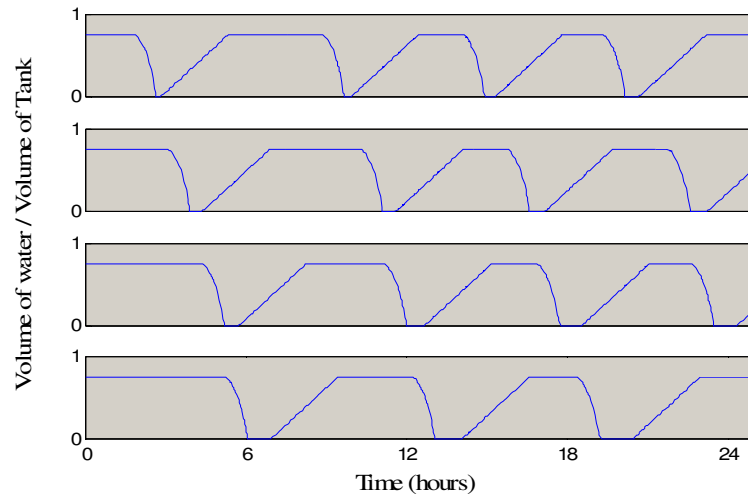

Figure 25. Volume of water (as a percent of tank volume) in each of the four tanks. Out of phase relationship allows continual power output.

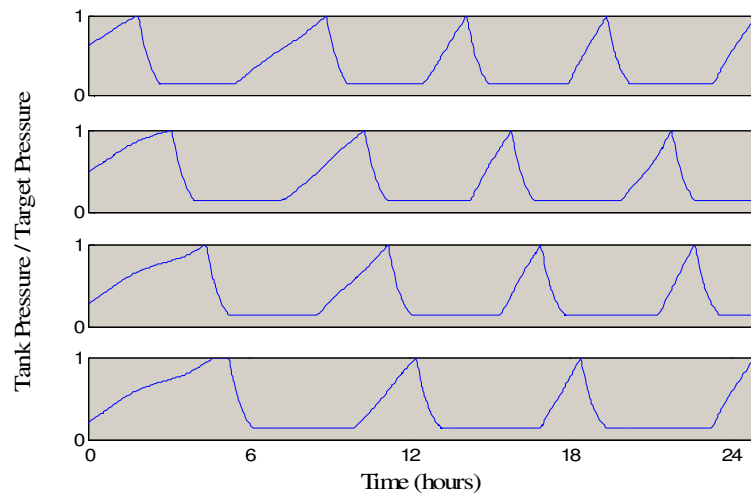

Figure 26. Pressure status in each of the four tanks. As one tank is discharging and dropping pressure, the others are receiving power input and their pressure is increasing.

The energy input for this simulation was still 134 MW-h. While this equates to an efficiency of 65.7%, the value of energy must be considered when making decisions concerning the effectiveness of this system.

It should be noted that any energy storage system comes at a price of reduced delivered energy. Energy losses in the compressor due to mechanical inefficiencies and heat transfer, as well as inefficiency in the turbine and generator add up to a reduced overall capacity factor for the system. The efficiency of these simulations only considers the losses associated with the venting algorithm; all heat transfer was assumed to be adiabatically recaptured in the cycle. This issue is the subject of continuing research and is recognized as an important performance factor in assessing storage methods and specific designs. However, it should be noted that capacity factor is not the only means to gauge performance. Dispatchable energy is more valuable to grid operators than non-dispatchable. By having the knowledge of when this system will go online, and with exactly what power capacity and duration, makes its energy more valuable.

With increased renewable energy penetration onto the grid, it's not just the unpredictability of wind or solar energy that is a concern for the utility. Certain events can occur during normal operation of a wind farm that greatly strain the utility. For example, if a wind farm is experiencing high winds, the turbines are producing a considerable amount of power. If a wind gust, even a very short one, sends the turbines past their cutoff speed, they enter a shut-down scenario. This is problematic to the utility because very rapidly they lose a significant amount of power being put on the grid. It can take up to 30 minutes for the turbines to come back online and begin producing power again. Through use of the proposed CF-CAES system, situations such as this could be drastically less problematic for the grid operator.

Merchant Storage Facility

Another application for the CF-CAES system is through use as a merchant storage facility. In this scenario energy is drawn from the grid during low cost, off peak hours and supplied during peak, high cost times. The two current compressed air energy storage systems in Germany and Alabama are both examples of this application.

Although power will still be drawn from the grid, the energy storage system can still be characterized as ‘carbon-free’ because during the energy recovery stage no natural gas combustion is required. In the simulation results shown below, 10.65 MW-h were input to the system during the evening and night. During peak demand, 7 MW-h were output, resulting in the same efficiency as in the previous two simulations: 65.7%. This consistent efficiency, independent of application and power output, is a function of alpha only.

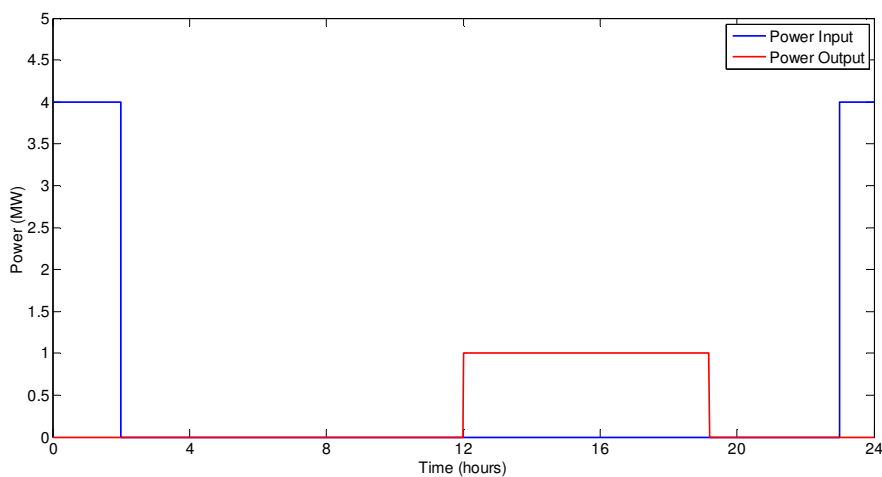

Figure 27. Merchant storage facilities store low-cost, off peak energy and sell it back in times of high demand.

A merchant storage facility operating in response to certain energy markets can not only effectively supply power when demand is high, but dynamically receive power as well. Throughout the course of the year, certain situations arise where wind farm/grid operators are forced to pay other utilities to take surplus power. These events correspond to times when many wind farms suddenly begin operating and demand is not high enough to balance the supply. As wind farms already operate under very small financial margins, paying another utility to take their sole commodity is very unfavorable. Contractual arrangements can be established with a merchant storage facility to provide a means of unloading power during these times at pre-established rates, thus greatly mitigating the loss associated with spot market rates.

CONCLUSIONS AND FURTHER RESEARCH

It is becoming widely recognized that a variety of solutions are present to the global energy issues that the world is facing. The need for investment in energy storage infrastructure is rapidly becoming evident.

The proposed energy storage system, Carbon-Free Compressed Air Energy Storage, presents a new technology that could be capable of meeting the integration burdens posed by renewable energy. For an energy storage system to feasibly mitigate these problematic issues, it must be able to do so without incurring too great a reduction in delivered energy. It must be efficient enough in order to be both technologically and economically feasible. Barriers exist which challenge the feasibility in both regards.

Technological Barriers

Application specific performance was simulated by implementing the results of the thermodynamic analysis into a fully functioning dynamic model. The required input of certain physical parameters into the model allowed the calculation of all other physical variables. Specifically, nozzle flow rate, compressor mass flow rate, and pumped water flow rate, which are initially dependent variables, were determined. No constraints were established to limit the bounds of these variables. As such, under certain conditions their values may be unrealistic.

Pelton Turbine

For an energy storage technology to be viable, the power level that it can deliver the stored energy is a very important parameter. In the case of CF-CAES, power is delivered by means of a Pelton style hydroturbine, which are sized according to flow rate and pressure. Considering the high-head, low flow applications suitable for CF-CAES, this would result in a very unconventional turbine design: very large diameter, small cup geometry. Several immediate options exist in approaching this barrier: custom turbine design, parallel/series operation, or re-evaluation of energy removal technique. Further research is necessary to undergo complete mechanical design of the system and establish appropriate constraint on flow rate.

Tank Size

The two competing factors governing tank size are internal pressure and volume. For large scale energy storage, it is desirable for both parameters to be as great as possible. It is no surprise that they are not only proportional to cost, but quickly reach bounds that limit design adjustments for both. Because of this limitation on a single tank design, further research needs to confront the issues associated with multiple tanks used for a single CF-CAES system. Tube trailers were investigated as a scalable means to store large quantities of compressed air, with a separate large tank containing water. However, as an air/water interface would still need to exist, the tank containing water would still be under the high pressure of the air and thus, must be sized accordingly.

Roundtrip Efficiency

An upper bound in roundtrip efficiency is dictated by the venting algorithm: the mass of compressed air that is transferred to a second tank allowing water to be pumped back into the initial tank is either vented or used in another process. The actual efficiency of the system would be a function of the thermodynamic process and the unavoidable destruction of useful to energy to heat. Additionally, each component in the system operates under its own efficiency, which must all be considered when establishing a roundtrip efficiency for the system. This study aimed to determine the maximum operating efficiency of the system under ideal conditions.

Economic Barriers

To assess the economic feasibility of CF-CAES, it must be viewed in the appropriate economic environment. A system such as this is designed proactively to be employed when conditions exist that require its application. There are unavoidable capital costs that pose considerable barriers; namely, those costs associated with the solutions to the aforementioned technological barriers. A newly designed Pelton turbine is a considerable cost, particularly when noted that its only likely application is in an emerging technological market. Likewise, great expense can be accrued in the design and fabrication of specialized tanks, piping, and manifolds to enable a sophisticated air/water interface.

In addition to the economic barriers associated with capital costs, there are barriers to the acceptance and integration of energy storage into various utilities energy

portfolios. Pricing schedules, required performance metrics, and development costs are all hurdles that the energy storage industry is overcoming.

It is evident that barriers exist to the development of this technology, but they can be confronted with increased research and design. Additionally, the heightened necessity of energy storage as a facilitator to renewable energy integration will aid to increase its potential. Large scale energy storage technology has the opportunity to enable levels of renewable integration into the national grids necessary for their objectives to be met.

REFERENCES

1. *20% Wind Energy by 2030: Increasing Wind Energy's Contribution to U.S. Electricity Supply*. July 2008. U.S. Department of Energy, Office of Energy Efficiency and Renewable Energy.
2. *The VRB Energy Storage System (VRB-ESS)*. 2007, VRB Power Systems, Inc.: Richmond, BC. p. 12.
3. van der Linden, S., *Bulk energy storage potential in the USA: current developments and future prospects*. *Energy*, 2006. 31: p. 3446-3457.
4. Cavallo, A., *Controllable and affordable utility-scale electricity from intermittent wind resources and compressed air energy storage (CAES)*. *Energy*, 2007. 32: p. 120-127.
5. Bullough, C., C. Gatzen, and C. Jaikiel. *Advanced adiabatic compressed air energy storage for the integration of wind energy*. *European Wind Energy Conference & Exhibition*. 2004. London, UK.
6. Ramakumar, R. *Energy storage options of harnessing wind energy*. in *5th Annual Energy Sources Technology Conference and Exhibition*. 1982. New Orleans, LA: American Society of Mechanical Engineers.
7. Enis, B., P. Lieberman, and I. Rubin, *Operation of hybrid wind-turbine compressed-air systems for connection to electric grid networks and cogeneration*. *Wind Engineering*, 2003. 27(6): p. 449-459.
8. Castronuovo, E. and J. Lopes, *Optimal operation and hydro storage sizing of wind-hydro power plant*. *Electrical Power and Energy Systems*, 2004. 26: p. 771-778.
9. Mears, L., H. Gotschall, and H. Kamath, *EPRI-DOE Handbook of Energy Storage for Transmission and Distribution Applications*. 2003, Electric Power Research Institute: Concord, ,CA.
10. Mears, L., et al., *Energy Storage for Grid Connected Wind Generation Applications*. 2004, Electric Power Research Institute: Concord, CA.

11. Bell, T., *Natural energy conversion, storage and electricity generation system*, U.P. Office, Editor. 1980: USA. Patent #4206608.
12. Gardner, J., *Underground pumped liquid energy storage system and method*, U.P. Office, Editor. 1980, Oros Company: USA. Patent #4182128.
13. Heidenreich, D., *Compressed air pumped hydro energy storage and distribution system*, U.P. Office, Editor. 2007, EB Group, Inc. Patent #7281371.
14. Energy Storage Association website. Visited 10/17/08.
<http://www.electricitystorage.org>

APPENDIX

Matlab/Simulink Models

```

Initialization.m

%% Initialization File
% This File creates variables for the CF-CAES model
% simulations.

alpha=0.25; %Percent of initial water height to tank height
V_tank=1000; %Volume of tank [m^3]
P_high=204*101000; %Target Compression Pressure [Pa]204

%% Load Wind Data
load WindSpeed
load PowerCurve
WindPower=interp1(pcwind,pcpower,WindSpeed);
WindPower=WindPower*13; %Use 13 turbines

%% Generic Tank (Volume)
Vi_a=V_tank*alpha; %Initial Volume of Air in tank [m^3]
Vi_w=V_tank-Vi_a; %Initial Volume of water in tank [m^3]
alphaV=alpha*V_tank;
%% Compressor Initialization
Comp_EFF = 1; % Compressor efficiency for 1st stage
n = 1.4; % polytropic constant for compression process

T_i=300; %K
%% Pelton Initialization
Pelton_Eff=1; %Efficiency of Pelton wheel, 0.6
%% Physical Parameters
rho_w=1000; %Density of water [kg/m^3]
g=9.81; %Acceleration due to gravity [m/s^2]

%Properties of Air
Cv_a=0.7179; %[kJ/kg-K]
Cp_a=1.005; %[kJ/kg-K]
k_a=Cp_a/Cv_a;
R_a=Cp_a-Cv_a;
k=k_a;
%% Pressures
Patm=101000; %[Pa] Atmospheric Air Pressure
P_res=P_high*alpha^1.4; %Residual Pressure in the Tank after Expansion
[Pa]
P_i=P_res; %Initial pressure in tank
P_inlet=Patm; %Compressor Inlet pressure

m_i=(P_i*V_tank)/(RGAS*T_i);
C=P_i*(V_tank/m_i)^k_a;
%%
save Logic_Init alpha P_i P_high P_res V_tank
global alpha P_i P_high P_res V_tank alphaV

```

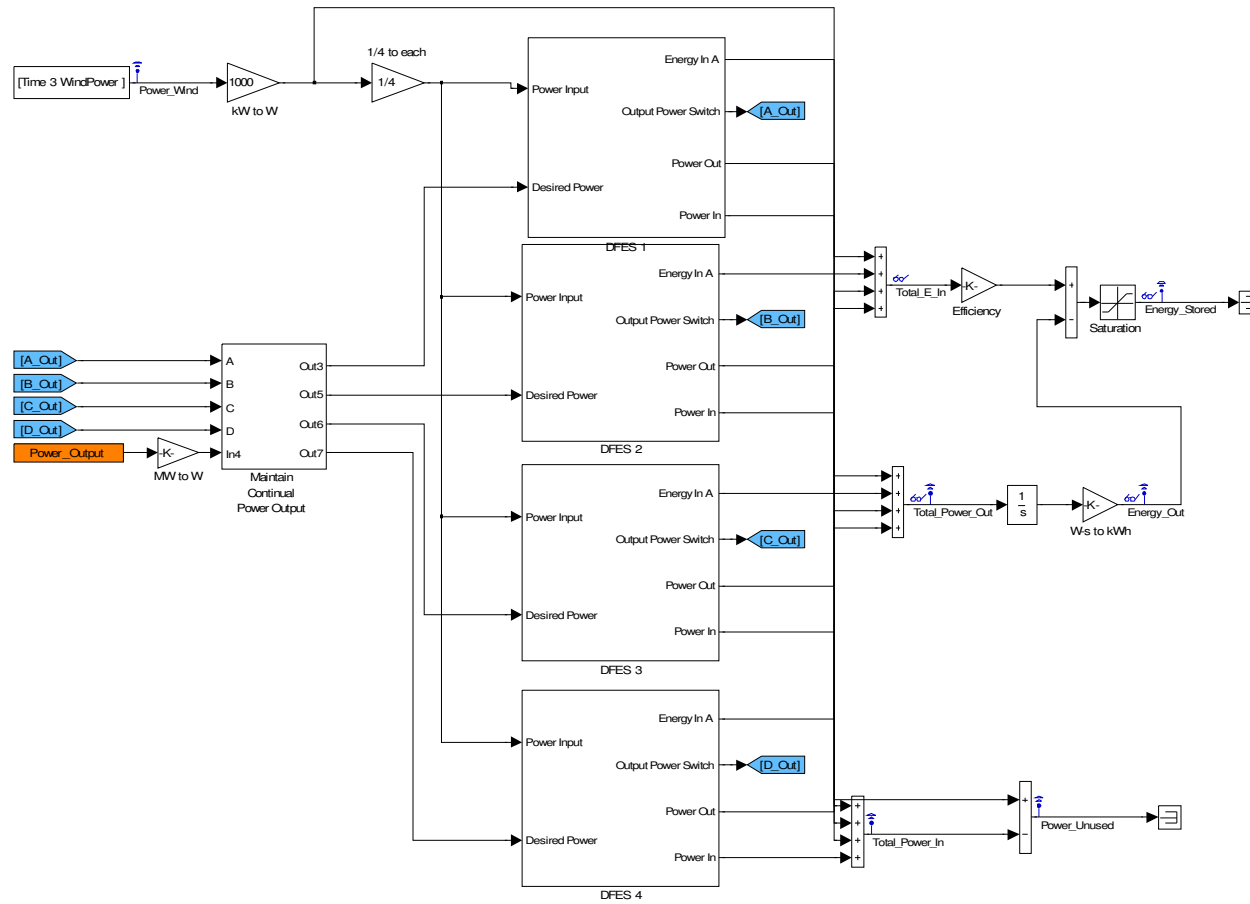

Figure A. 1 Simulink model of a four system batch operation

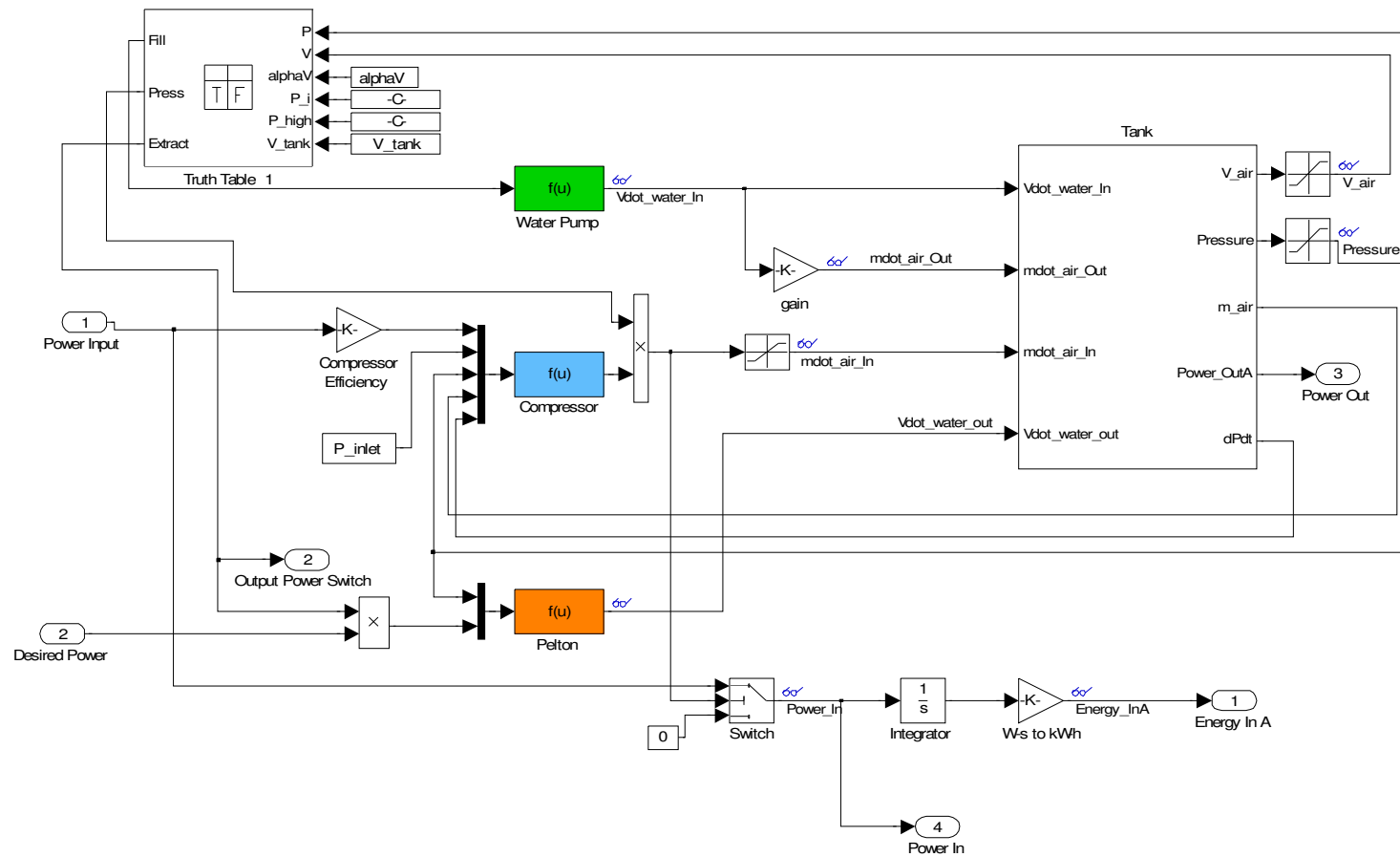

Figure A. 2 Single System Model

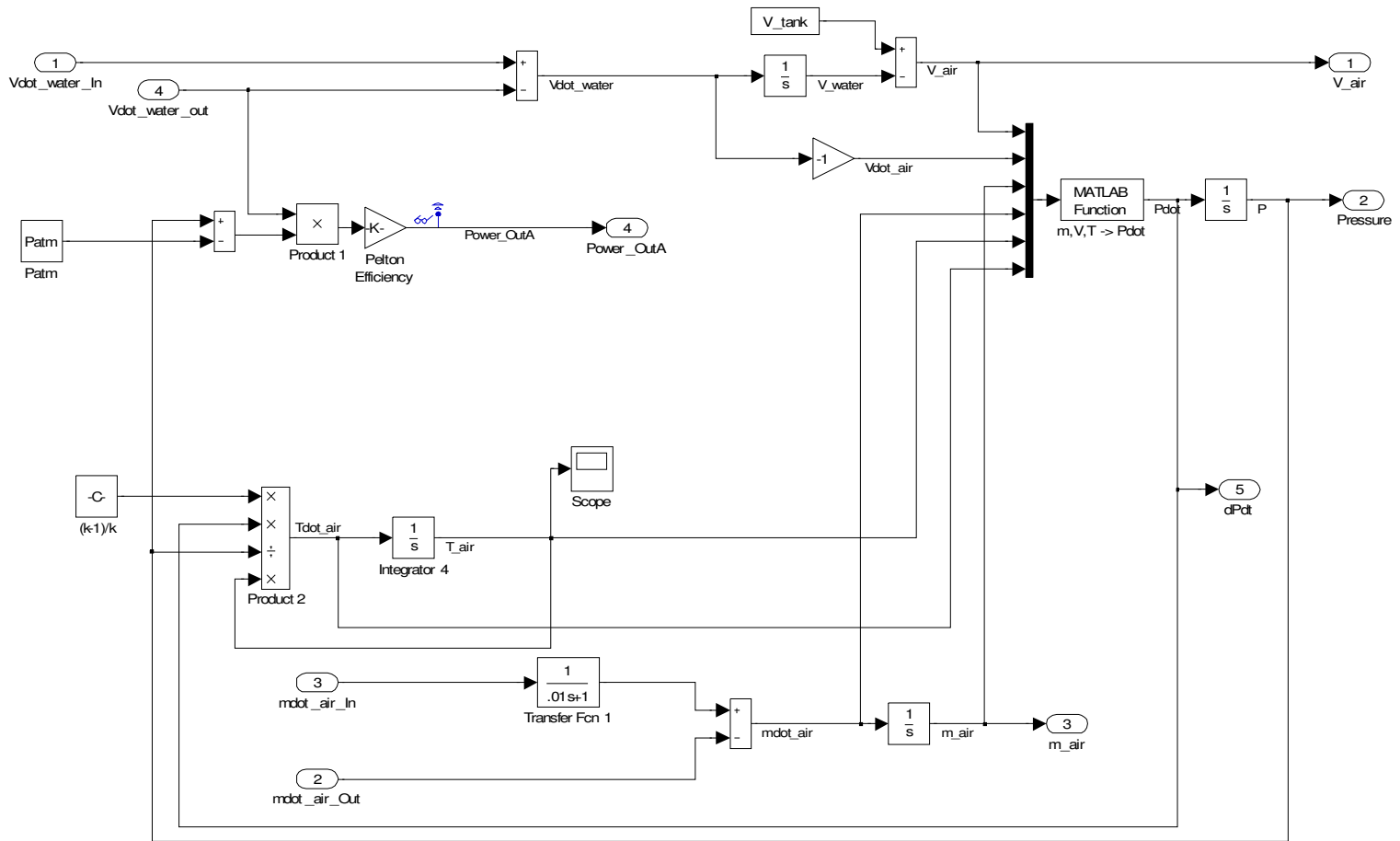

Figure A. 3 Tank Model

