

Boise State University

ScholarWorks

Public Health and Population Science Faculty
Publications and Presentations

School of Public and Population Health

2013

Extending Global Education Through Remote Laboratory Access

Uwe Reischl

Boise State University

Scott Harris

Apriori LLC

Lecture Notes in Computer Science contains various volumes with individual titles. The title of this particular volume is *Digital Human Modeling and Applications in Health, Safety, Ergonomics, and Risk Management. Human Body Modeling and Ergonomics*.

Extending Global Education through Remote Laboratory Access

Uwe Reischl

Boise State University, Boise, Idaho, USA
ureischl@boisestate.edu

Scott Harris

Apriori LLC, Boise, Idaho, USA
sharris@reach-in.com

Abstract

Advanced software technologies that can be integrated with physical laboratories now allow students and researchers to access laboratory equipment and instruments remotely through the Internet. While this capability has been used in engineering and science education successfully for some time, application of this approach to human factors engineering and ergonomics education is new. The development of a remote ergonomics laboratory based on such an Internet technology is described. The focus of this new laboratory is to provide a method of evaluating protective clothing heat stress using a thermal manikin technology. The laboratory has generated global interest and created international collaboration in teaching and research.

Keywords: Remote laboratory, ergonomics education, thermal manikin, international collaboration

1. Introduction

The rapid expansion of the Internet and its growing popularity worldwide has had a significant impact on education. This technology offers new tools for a broad range of engineering and science disciplines. The technology also offers the opportunity to promote the development of new teaching strategies such as interactive experimentation, simulation, etc. (1). Broadband access and data compression support the delivery of audio and video streaming of lectures on the Internet. Computer and Internet based learning has become an important part of education internationally.

A special challenge for online education in the engineering, science, and technology fields is how to extend the traditional hands-on laboratory settings over the Internet. Hands-on laboratories have been an integral part of engineering programs (2). Concepts presented in lectures are often complemented with laboratory experimentation. Hands-on education allows students to experience the “backbone” of engineering and science by conducting experiments, observing dynamic phenomena, testing hypotheses, learning from their mistakes, and reaching their own conclusions (3). With the rapid advances in microprocessor and communication technologies, more and more equipment can now be reconfigured and controlled remotely. These developments have made hands-on training via the internet possible. Currently, there are two approaches to conducting labs online. These include virtual labs and remote labs

- Virtual laboratories are based on software to simulate the lab environment and are especially useful when equipment is too expensive, unsafe, or unavailable. Virtual labs allow students to repeat an experiment multiple times, giving them the chance to see how changed parameters and settings can affect the outcome. Students can learn from failures without causing real damage.
- Remote laboratories are facilities used to conduct experiments that are controlled remotely through the Internet. The experiments use real components and instruments at a different location from where they are being controlled from. The logistics of developing a real laboratory is often a significant problem for educational institutions because the availability of space is frequently limited, availability of funding for instrumentation and supporting equipment is limited, and the availability of technical support staff is also limited.

To promote student access to hands-on learning in the fields of ergonomics and human factors engineering, not only at the local level but also regionally and internationally, an existing thermal manikin laboratory at Boise State University was reconfigured to accommodate an Internet-based remote control technology. The laboratory now serves as an educational platform for academic partner institutions regionally and internationally.

2. Laboratory Implementation

The Ergonomics Laboratory is equipped with a thermal manikin system capable of assessing the heat exchange characteristics of protective clothing worn under controlled environmental conditions. Equipment includes a manikin air pressure system, manikin air heating system, environmental ventilators, infrared radiators, and digital thermometers measuring manikin input and output temperatures needed to compute the manikin heat gain or heat loss.

- Before the facility is ready for use as a remote laboratory, the IT infrastructure as it relates to the remote connections had to be solved. Factors such as network firewall policy or which software was going to be used for the connection and interface had to be resolved.
- Initiating a remote laboratory experiment required that all of the supporting staff as well as the students were fully aware of the experimental procedures, knowledgeable in using the remote controls properly and safely, and were aware of the time requirements associated in collecting accurate data.
- Assessing the learning outcome or value of the remote laboratory assignment required the collection and evaluation of feedback from the student users. This information was used to correct deficiencies and was used to modify the laboratory experience.

3. Remote Controls

The Internet platform serving the Remote Laboratory is provided by Apriori, LLC through its “Reach-In” browser technology which allows novice Internet users, i.e. users with no special computer skills, the ability to control mechanical devices through the internet using nothing more than their everyday computer and their everyday home Internet connections. This functionality is possible in any geographical location in the world that has Internet access. This technology platform provides major advantages for international collaboration in the following ways:

- The software reduces latency to less than 1 second based on the current Internet infrastructure.
- The software works in all major browsers without the need for special downloads.
- The software can control any hardware component over the web.
- The technology allows many users to interact on one site without compromising the quality for the user in control.
- A queuing methodology allows for global users to join a queue from anywhere on the Internet. This architecture accounts for every person in line and dynamically adjusts for variances in line positioning.

Any student or researcher with sufficient connection speed can log onto the remote laboratory website and control all of the assigned laboratory devices from anywhere in the worlds without a time delay. The user has the ability to control a camera, pan up and down, and zoom in and out on every instrument located in the laboratory. At a click of their mouse, a user can control up to 12 mechanical devices at any one time.

4. System Architecture

The key feature of this system lies in its architecture which minimizes the latency time of the hardware components and the latency of the software that controls the devices. A main server acts as a hub for all information transfer. A dedicated replication server is included that handles the video stream separately since the video stream represents the largest amount of data transfer. A camera is connected to an on-site control box. The mechanical devices in the laboratory are connected to motherboard located inside the control box which converts the digital data signals into voltage outputs. The voltage outputs act as the

driving force to articulate the geared camera hardware back and forth, up and down, on, and of, etc. A kernel of software is located on the control box that communicates with the main servers providing an “IsAlive” beacon. Service technicians can respond if the “IsAlive” beacon does not check-in within 15 seconds.

5. Laboratory Set-Up

The ergonomics laboratory contains an inflatable thermal manikin system designed to measure the heat transfer characteristics of clothing systems. The technical design features are illustrated in Figure 1. While the manikin needs to be clothed by a staff member, all controls required to operate the system can be manipulated remotely via the Internet. A student, or a researcher, logs on to the laboratory website and sees the laboratory “live” through a camera that is in the “ON” position 24/7 (Fig. 2). The user can then engage the manikin sub systems consisting of the manikin air pressure system and the manikin internal air heating system activated through by the power control relays (Fig. 3). This provides the “start-up” operating configuration for the manikin. The manikin must reach thermal equilibrium with the laboratory environment prior to testing. The user can then operate the laboratory IR exposure lamps and the laboratory cooling fans to change the manikin exposure conditions. Using the camera’s directional controls and the “zoom” feature, the user can monitor the digital thermometers that display the manikin input air temperature as well as the manikin output air temperature (Fig. 4). These values are then used to calculate the heat loss or heat gain exhibited by the manikin during exposure to different environmental conditions or clothing configurations. The laboratory remote control schematic illustrating the relationship between the key components and the sub-systems of the laboratory are illustrated in Fig 5.

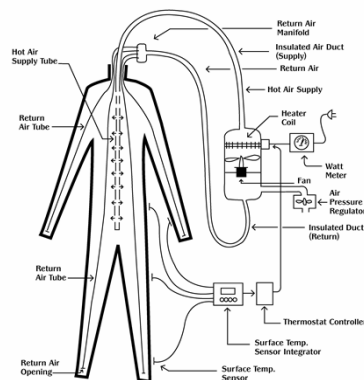

Fig. 1. Illustration of the inflatable thermal manikin system.



Fig.2. Remote controlled internet camera allowing un-interrupted visual access to the laboratory.



Fig. 3. Remote control relays used in activating power to thermal manikin sub-systems.



Fig. 4. Temperature monitors showing manikin input air temperature and manikin output air temperature values which are needed to compute manikin heat loss values.

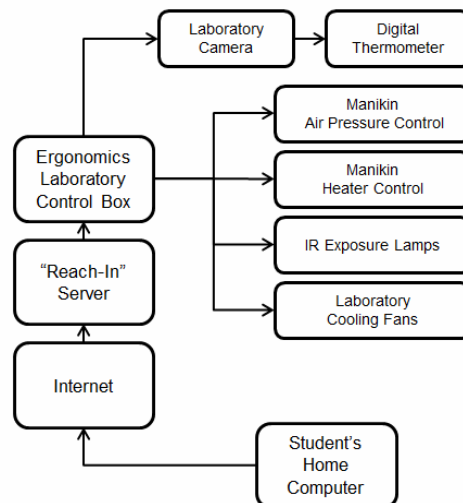

Fig. 5. Layout for of the laboratory remote control system.

6. Conducting an Experiment

To determine the heat transfer characteristics of a garment requires the student or researcher to perform two measurement conditions sequentially using the following steps as illustrated schematically in Fig.6:

- The thermal manikin must first reach thermal equilibrium in a “semi-nude” configuration (wearing short pants only). This serves as the “control” configuration (Fig. 7A).
- The temperature difference between output air and input air is observed and recorded and entered into a standard energy loss calculation.
- Once thermal equilibrium is reached, heat radiation exposures or wind conditions can be added. Again, the manikin input and output temperature values are recorded at equilibrium.

- To measure the thermal characteristics of clothing systems, the procedures used for the “control” conditions are repeated with the exception that the manikin is now clothed (Fig. 7B)
- The energy loss values are then compared to the “control” conditions. This provides the student or researcher accurate values for the thermal properties of the clothing system.

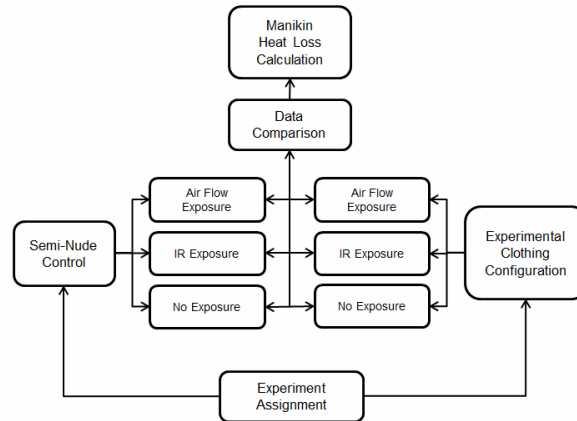

Fig. 6. Testing protocol schematic

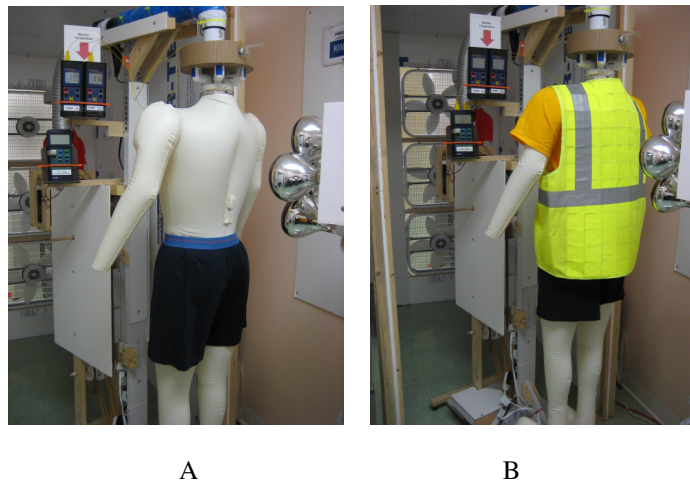

Fig. 7. Illustration of thermal manikin in a semi-nude “Control” configuration (A) and in the “Experimental” configuration (B).

7. Use of Laboratory

Access to the remote thermal laboratory is currently open to the global Internet community. Visitors are permitted to operate the equipment “at-will” to observe the technical functions of the key manikin equipment. User tracking has shown that persons from all continents around the world have accessed the facility either as a viewer or as an active “player” operating the various manikin sub-systems. Although the current features appear to offer visitors a video-game “entertainment” opportunity, the goal of the open access policy is to promote interest in ergonomics research. However, when experiments are being conducted locally or “in-house”, the remote controls are disabled. This allows the researchers to eliminate outside interference or interruptions. However, the camera continues to remain “on” during experiments which allows visitors anywhere in the world to view these activities 24/7.

8. International Collaboration

International use of the remote thermal manikin laboratory as a research facility developed after visiting researchers successfully conducted in-house studies using the thermal manikin technology and wanted to continue with their experiments after returning home. The collaborations have now expanded from Boise State University in the USA to the University of Zagreb in Croatia and the Hong Kong University of Science and Technology. Preliminary collaborations are being explored with universities in Brazil and in Peru. Although the advantage of using the remote laboratory increases with distance, differences in the East-West time-zones can make real-time communications regarding experimental problems and set-up requirements difficult. Nevertheless, as academic resources become scarcer, collaborative use of laboratory resources locally, regionally, and internationally will be helpful. Remote laboratories will undoubtedly play an important role in promoting collaboration.

References

1. Selmer, A., Kraft, M., Moros, R., and Colton, C.: "Weblabs in Chemical Engineering Education. *Education for Chemical Engineers*, 2, 38-45 (2007)
2. Feisel, L. and Rosa, A.: The Role of the Laboratory in Undergraduate Engineering Education. *Journal of Engineering Education*, 94, 121-130 (2005)
3. Tompkins, P.A., and Pinggen, G.: "Real-Time Experimentation Across the Internet." *Physics on the Internet*, 40(1), 408-410 (2002)